

**KYODO**

**UHF FM MOBILE RADIO**  
**KG107-40A/B/C/D/E/F**  
High Power Model

15-30W  
335-370MHz  
360-400MHz  
400-440MHz  
440-480MHz  
470-512MHz  
480-520MHz

**SERVICE MANUAL**



It will be understood that this Manual covers the description of operation and maintenance services of the KG107 series models as listed in the following table:

Model	Frequency Range	Channel Spacing	RF Power Output
KG107-40A30KW	335 – 370 MHz	20/25/30 kHz	15 – 30 watts
KG107-40A30KN	335 – 370 MHz	12.5 kHz	15 – 30 watts
KG107-40B30KW	360 – 400 MHz	20/25/30 kHz	15 – 30 watts
KG107-40B30KN	360 – 400 MHz	12.5 kHz	15 – 30 watts
KG107-40C30KW	400 – 440 MHz	20/25/30 kHz	15 – 30 watts
KG107-40C30KN	400 – 440 MHz	12.5 kHz	15 – 30 watts
KG107-40D30KW	440 – 480 MHz	20/25/30 kHz	15 – 30 watts
KG107-40D30KN	440 – 480 MHz	12.5 kHz	15 – 30 watts
KG107-40E30KW	470 – 512 MHz	20/25/30 kHz	15 – 30 watts
KG107-40E30KN	470 – 512 MHz	12.5 kHz	15 – 30 watts
KG107-40F30KW	480 – 520 MHz	20/25/30 kHz	15 – 30 watts
KG107-40F30KN	480 – 520 MHz	12.5 kHz	15 – 30 watts

#### 4. CIRCUIT DESCRIPTION

##### 4-1 RX Section

The RF input signal incoming from the antenna passes through the lowpass filter, the antenna relay, and the bandpass filter (BPF-1) in succession to undergo amplification by Q1. The amplified signal passes through the bandpass filter (BPF-2) to be applied as the input to the DBM-1 (diode, double-balanced mixer).

The DBM-1 is to mix the amplified RF signal with the 1st local oscillator (LO) signal to develop the 1st IF signal at 21.6 MHz as its mixed output.

The output signal is further amplified by Q2, followed by still further amplification by Q3 after the initially amplified signal being applied to the crystal filter (XF-1). The finally amplified signal is applied to IC-1 as its input. At IC-1, the 1st IF signal at 21.6 MHz is converted into 455 kHz through the 2nd mixer. The 455 kHz signal passes through the 455 kHz ceramic filter (CF-1) to obtain an AF signal via the limiting amplifier and discriminating circuit.

The AF signal is then separated into the audio signal and the noise signal necessary for squelch control.

The audio signal passes through the lowpass filter (IC-2 (1/2)), the delay circuit consisting of Q6, Q7, and IC-3, and the lowpass filter (Q8) for application to DC-controlled volume control IC-4.

The output signal from IC-4 passes in succession through the high-pass filter of IC-5 (1/2), the integrating circuit of IC-5 (1/2), and the squelch gate circuit (Q10) to undergo power amplification by IC-6. The power-amplified signal is applied to the speaker to radiate acoustic energy therefrom.

The squelch noise signal undergoes amplification by IC-1 and IC-2 (1/2) and detection by DC, to become a DC signal.

The DC signal passes through the switching circuit consisting of IC-1 and Q4 to obtain the input to the microcomputer (IC403).

The microcomputer develops the squelch gate signal as its output depending on the status.

#### 4-2 TX Section

The transmit signal from the PLL (phase-locked loop) unit undergoes amplification by Q201 and IC201 and further power amplification by Q204. The amplified signal emerges, via the relay circuit and the lowpass filter, from the antenna as its output. Part of the output is detected by D203 to drive the APC circuit consisting of IC202 (1/2) and Q203 and to obtain the rated output.

In cases where reflected powers are predominant or the ambient temperature rise is excessive, both Q205 and Q206 initiate operation, thereby reducing the TX output for the protection of the TX section.

#### 4-3 Modulator Section

The audio signal incoming from the microphone undergoes AGC amplification and further amplification by IC408 and IC8 (1/2). The amplified audio signal passes through the pre-emphasis circuit consisting of C76 and R84 before it is amplitude-limited by the limiting amplifier IC8 (1/2). The amplitude-limited signal passes through the lowpass filter consisting of L9 and L10 to become a modulating signal to be applied to the gate of TX VCO FET (Q302).

#### 4-4 VCO Section

This section incorporates two oscillation circuits, Q301 and Q302. Whereas Q301 (RX VCO) is for use with RX 1st local oscillator (LO) (F-21.6 MHz), and Q302 (TX VCO) is to initiate oscillations at the transmit frequency.

These oscillators can be switched over by means of the press-to-talk switch, Q306, and Q309.

Either oscillator output is amplified by the buffer amplifier (IC 301) to become the input signal to RX 1st LO (Q303), TX amplifier (Q304) and a part of the prescaler (IC104). The RX LO signal is amplified by Q303 to cause the 1st mixer DBM-1 to drive.

The transmit signal is amplified by Q304 and the amplified signal becomes the input signal to the TX section. The PLL circuit when unlocked causes Q305 and Q308 to operate, thereby turning "OFF" the TX output.

#### 4-5 PLL Section

On designating the address data of EP-ROM IC101 corresponding to channel number by the microcomputer IC403, the data signal goes to PLL IC102 as its input.

The PLL IC102 is to frequency divide both the reference frequency and the frequency incoming from the VCO in accordance with the ROM data and to develop their difference frequency output, thereby controlling the VCO oscillation frequency.

The 1.5 MHz reference frequency is obtained by dividing the 12.00 MHz oscillation frequency of TCXO (X101) into one-eighth (1/8) by means of IC103.

The VCO signal undergoes frequency division of 1/64 and 1/65 by prescaler IC104 and these signals are applied to the PLL IC as its inputs.

## 5. MAINTENANCE INSTRUCTIONS

### 5-1 General

The KG107 radio has been designed to ensure a high degree of reliability over a long trouble-free service life without maintenance efforts.

However, occasional inspections and adjustments are required to maintain the radio in the optimal conditions.

### 5-2 Necessary Tools and Measuring Equipment

It is recommended that the undermentioned measuring equipment and maintenance tools be properly stored in your maintenance shop for ready use

1. Circuit Tester
2. RF Power Meter
3. Vacuum-Tube Voltmeter
4. AF Generator (600 ohms, 100 through 10,000 Hz)
5. Linear Detector
6. Distortion Meter/Level Meter
7. Directional Coupler
8. Standard Signal Generator
9. Frequency Counter
10. Spectrum Analyzer

### 5-3 Precautions in Inspection and Adjustments

1. Always use standard-tip screwdrivers that best fit core slots in adjustment. Be very slow and cautious in turning the cores.
2. In adjusting the VCO, never turn trimmer capacitors or cores with an ordinary screwdriver. Be sure to use an RF screwdrivers. Otherwise, adjustments may result in failure due to the effect of stray capacitances.
3. Keep all measuring instruments calibrated at all times for availability of accurate measurements.

### 5-4 Adjustment Items and Procedures

All items, 5-4-1 through 5-4-3 that follow, have been precisely adjusted at our factory before shipment.

Need for readjustment of these items at site might arise depending on the circumstances, except that need for readjustment will seldom occur as to items 5-4-3 (3) and (4).

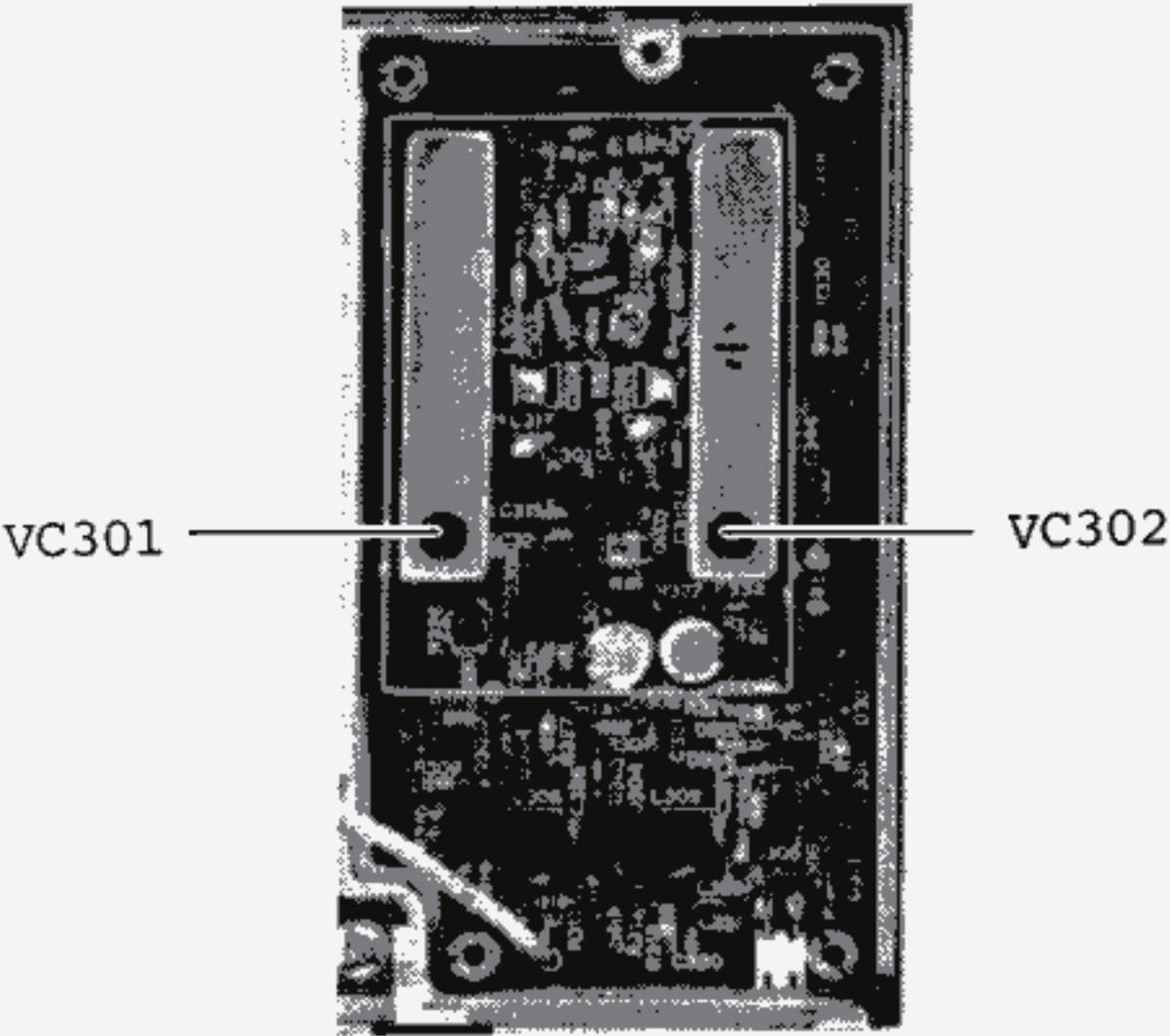

1. Receive VCO Adjustment

Connect a voltmeter to TP103 on PLL Unit and adjust Trimmer Capacitor VC301 with a coredriver to read 3V on the voltmeter.

2. Transmit VCO Adjustment

Put the KG107 in transmit mode and adjust Trimmer Capacitor VC302 to read 3V on a voltmeter connected to TP103.

3. Verification of Transmit (Receive) Frequency

Under TX mode, verify transmitting frequency. If within  $\pm 1$  ppm at room temperature, it's OK. Never turn trimmer capacitor in TCXO.

If tolerances of  $\pm 1$  ppm are exceeded, readjust the transmit frequency by turning the trimmer capacitor.

After verification, apply a signal from the standard signal generator to the antenna to see that the receiver remains fully sensitive when a programmed frequency signal is applied to the receiver.

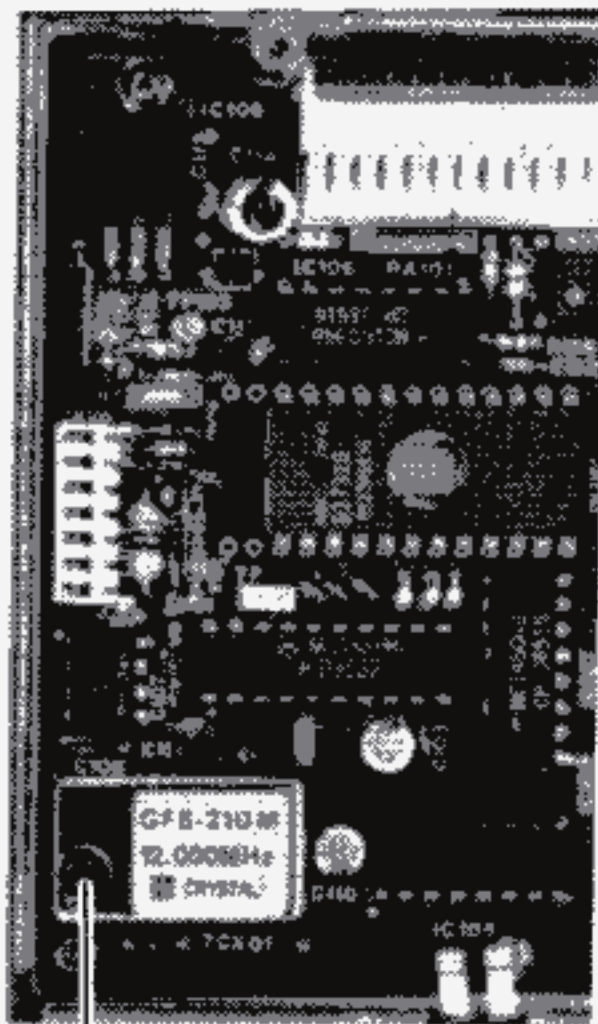

TCXO



(Note that the foregoing also serves for verification of EP-ROM programs.)

**PRECAUTIONS:**

The radio performs trouble-free operation within the VCO voltage range, 1 to 5V, as read on a voltmeter connected to TP103.

Adjust trimmer capacitor to read 3V (mid-position) on the voltmeter in case of single channel.

In case of multichannel, verify VCO voltages for the lowest and the highest frequencies and perform centering so that all fall between 1 and 5V.

Note that the frequency vs. VCO voltage curve inclination of RX is steeper than that of TX (i.e., the bandwidth of RX is narrower).

Be sure to refer to the characteristic curve in adjusting RX.

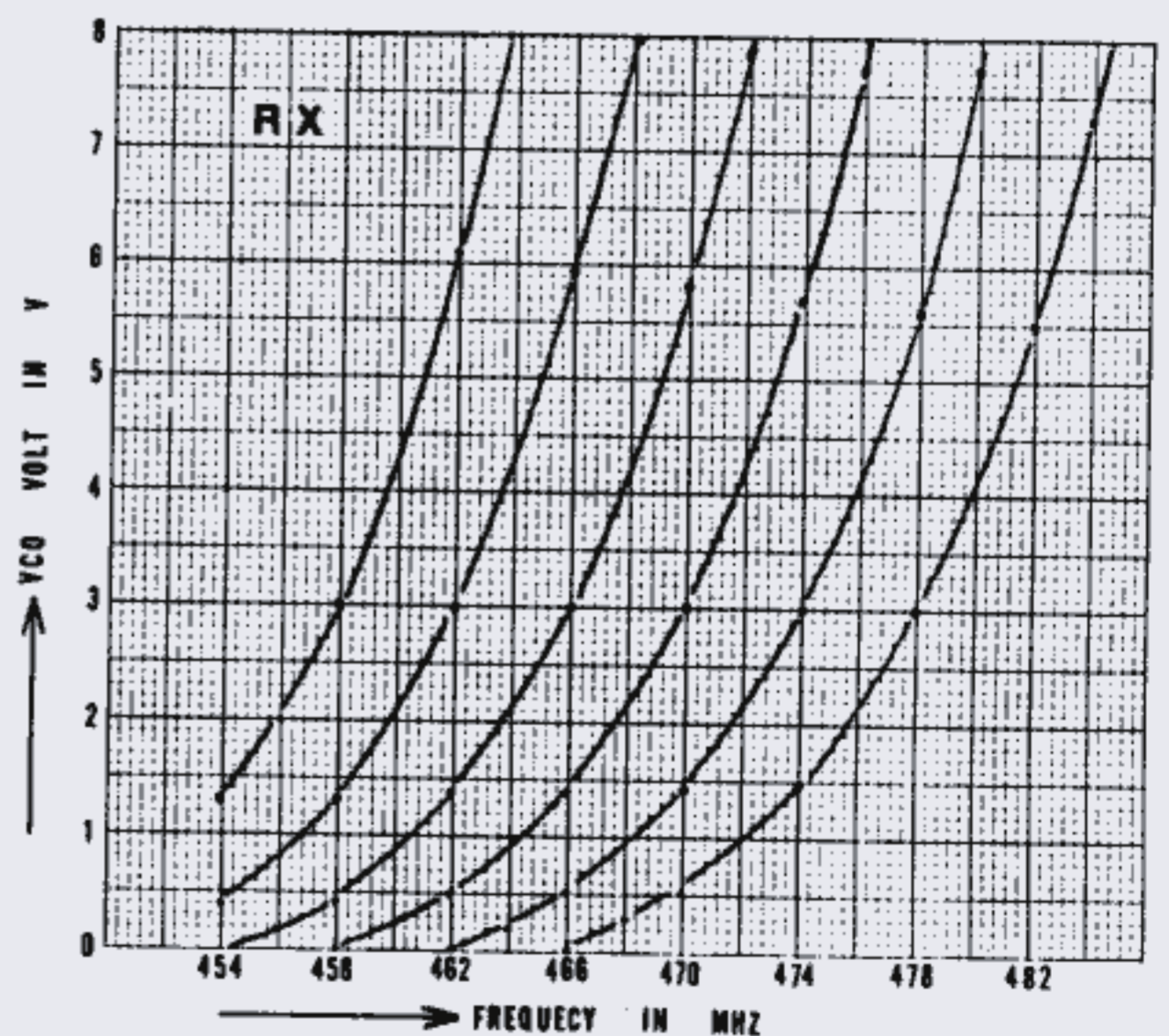
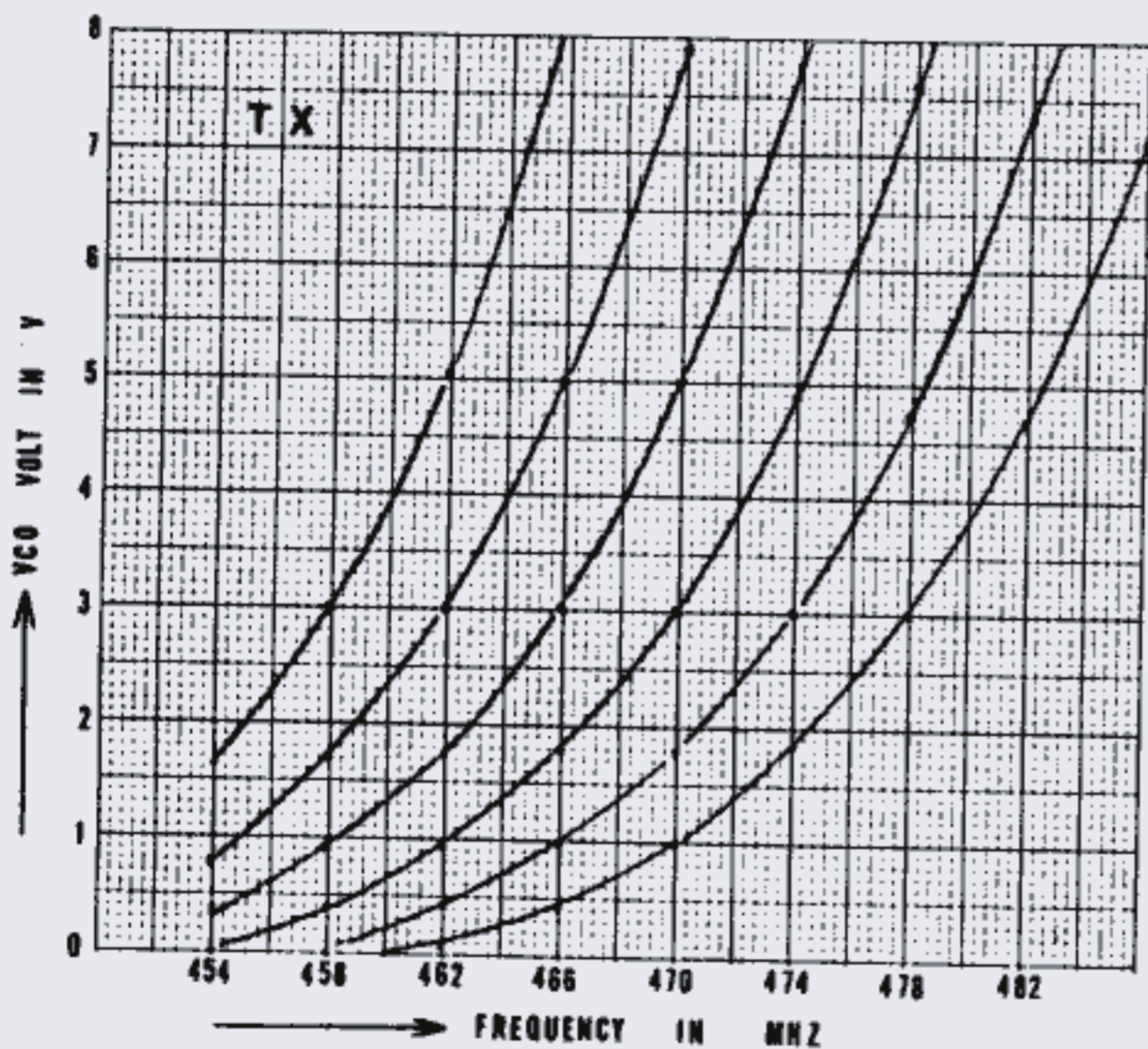

## 5-4-2 Adjustments of RX Section

### 1. RF Stage Adjustment

Adjust BPF1 and BPF2 for maximum sensitivity points (with a screwdriver).

A better result can be obtained by measurement using a tracking generator.

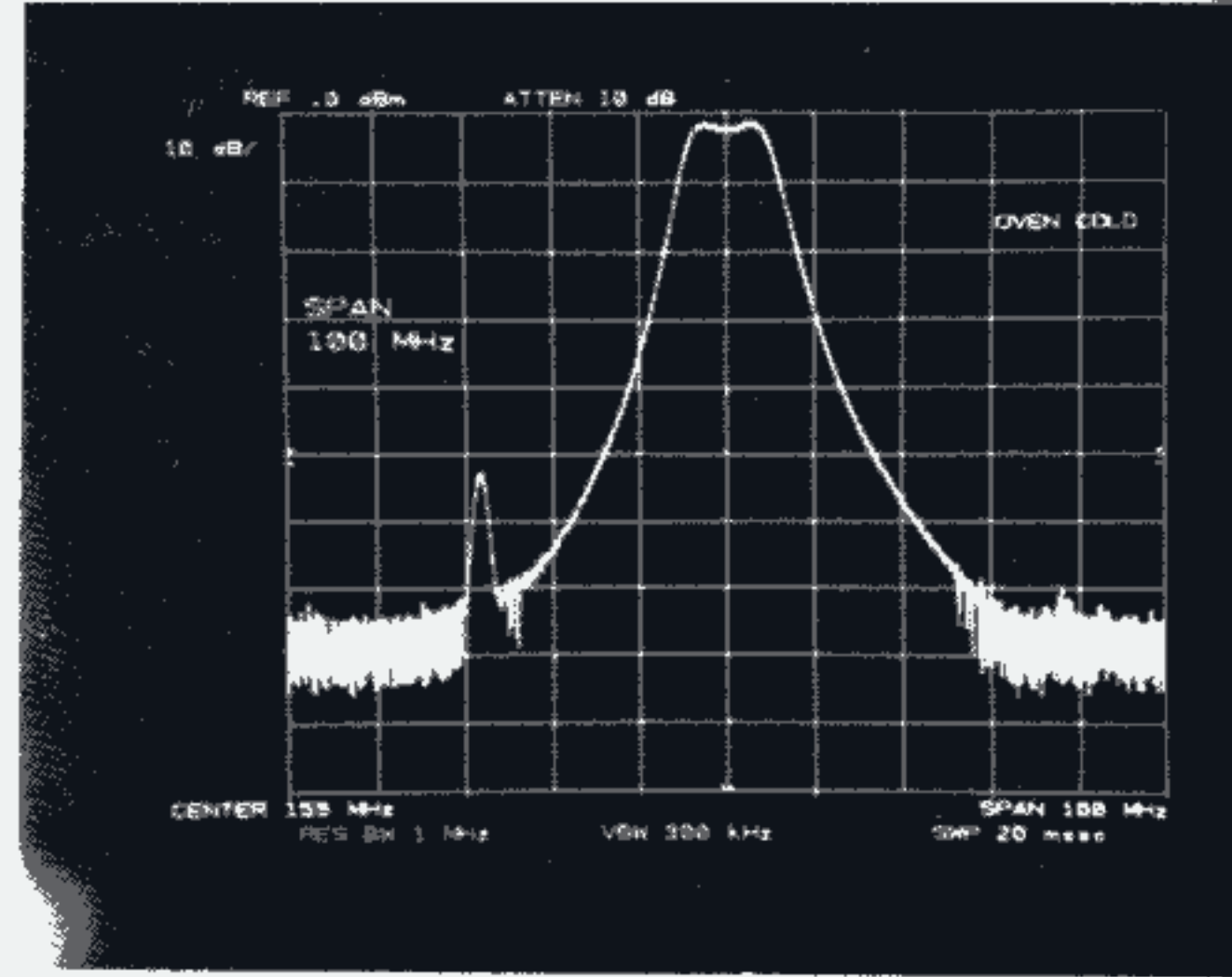
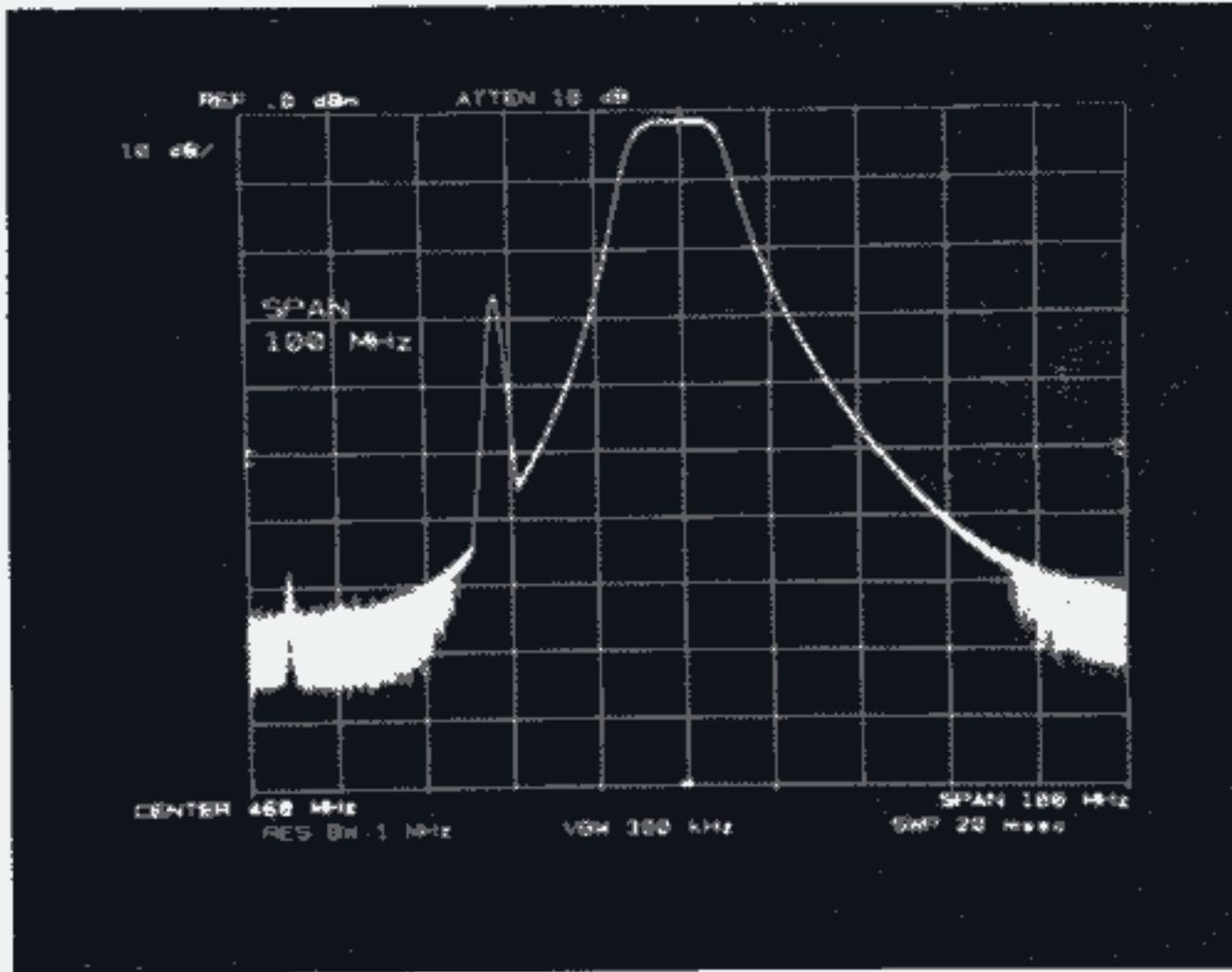

UHF (468 MHz)

VHF (155 MHz)

### 2. IF Stage Adjustment

- (1) L3: Adjust to sensitivity maxima.
- (2) T1, T2 Adjust to SINAD sensitivity maxima, with 1 kHz, and T3: 70% MOD signal applied to Antenna.

### 3. AF Stage Adjustment

- (1) Volume : Set FVR2 to 4W/4Ω, with tone control turned fully clockwise and 1 kHz, 50% MOD signal applied to Antenna.
- (2) Squelch : Adjust FVR1 for 20 dB Noise Quieting Input, with squelch control turned fully clockwise.

(3) Clock Oscillation:

Verify clock oscillation frequency falls within 12.5 kHz  $\pm$ 2 kHz, with Frequency Counter connected to TP1.

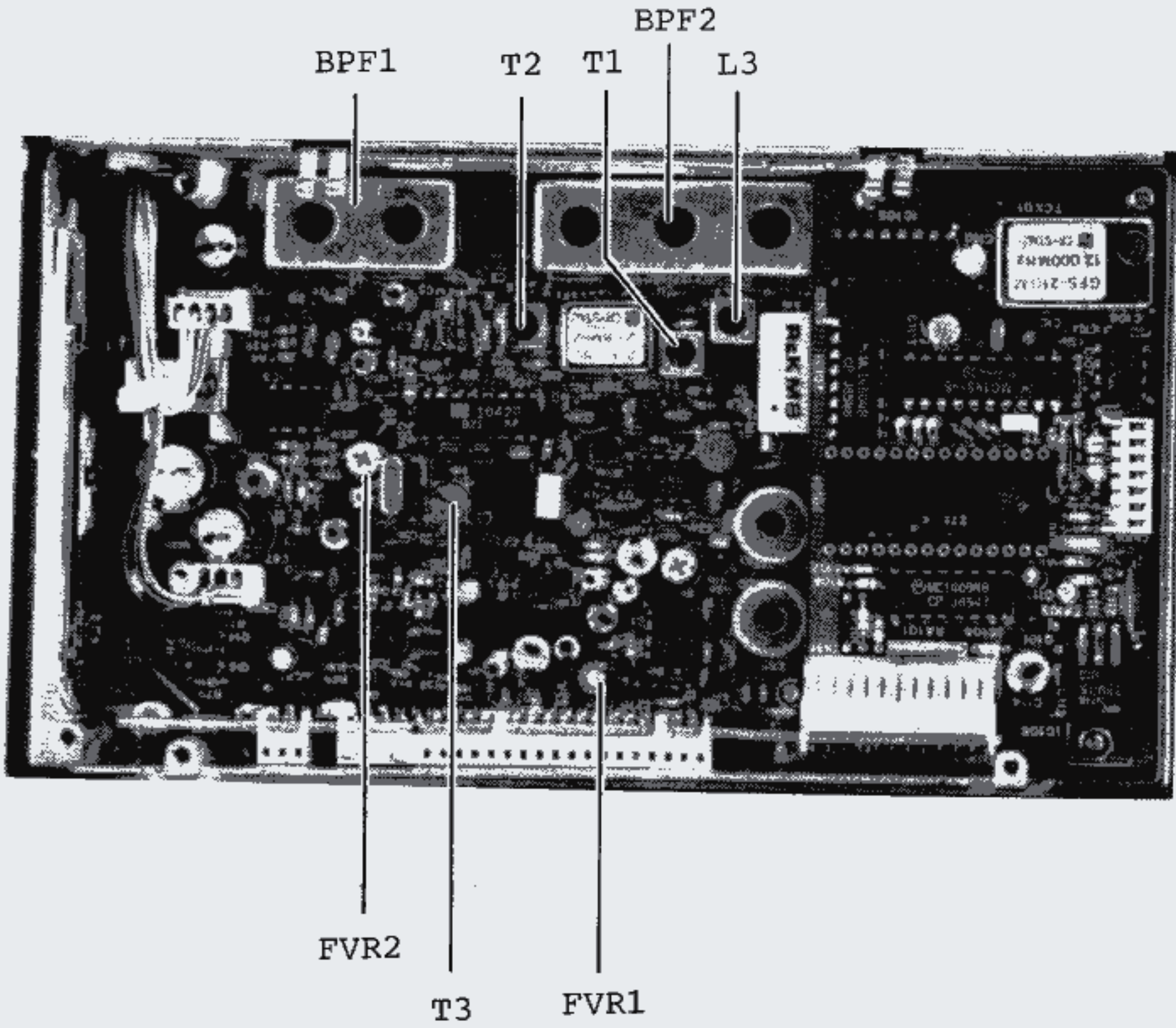

### 5-4-3 Adjustments of Transmitter Section

#### (1) Transmitter Output:

Adjust power with FVR201 in PA. Turning clockwise decreases power.

#### (2) Frequency Deviation:

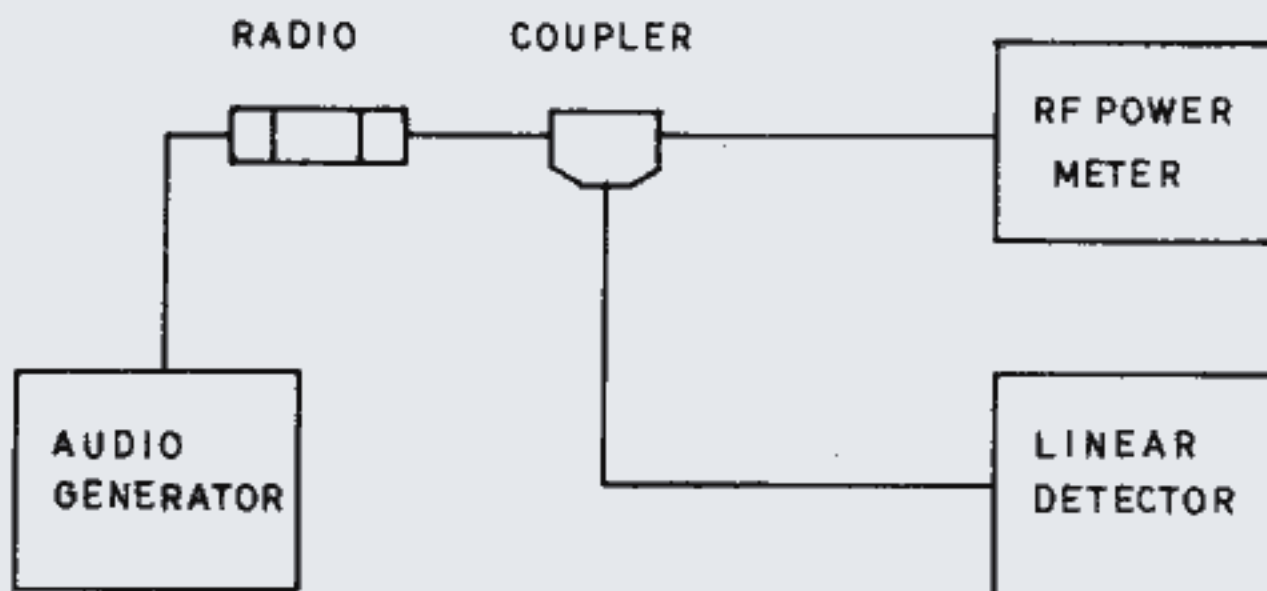

Connect Linear Detector to 20 dB pad, apply -14 dB, 1 kHz signal from microphone connector.

Then, adjust FVR4 to obtain a reading of 5 kHz (at max.) on the linear detector.

Further, adjust FVR3 to make the deviation 3 kHz, with input level down to -34 dBm (1 kHz).

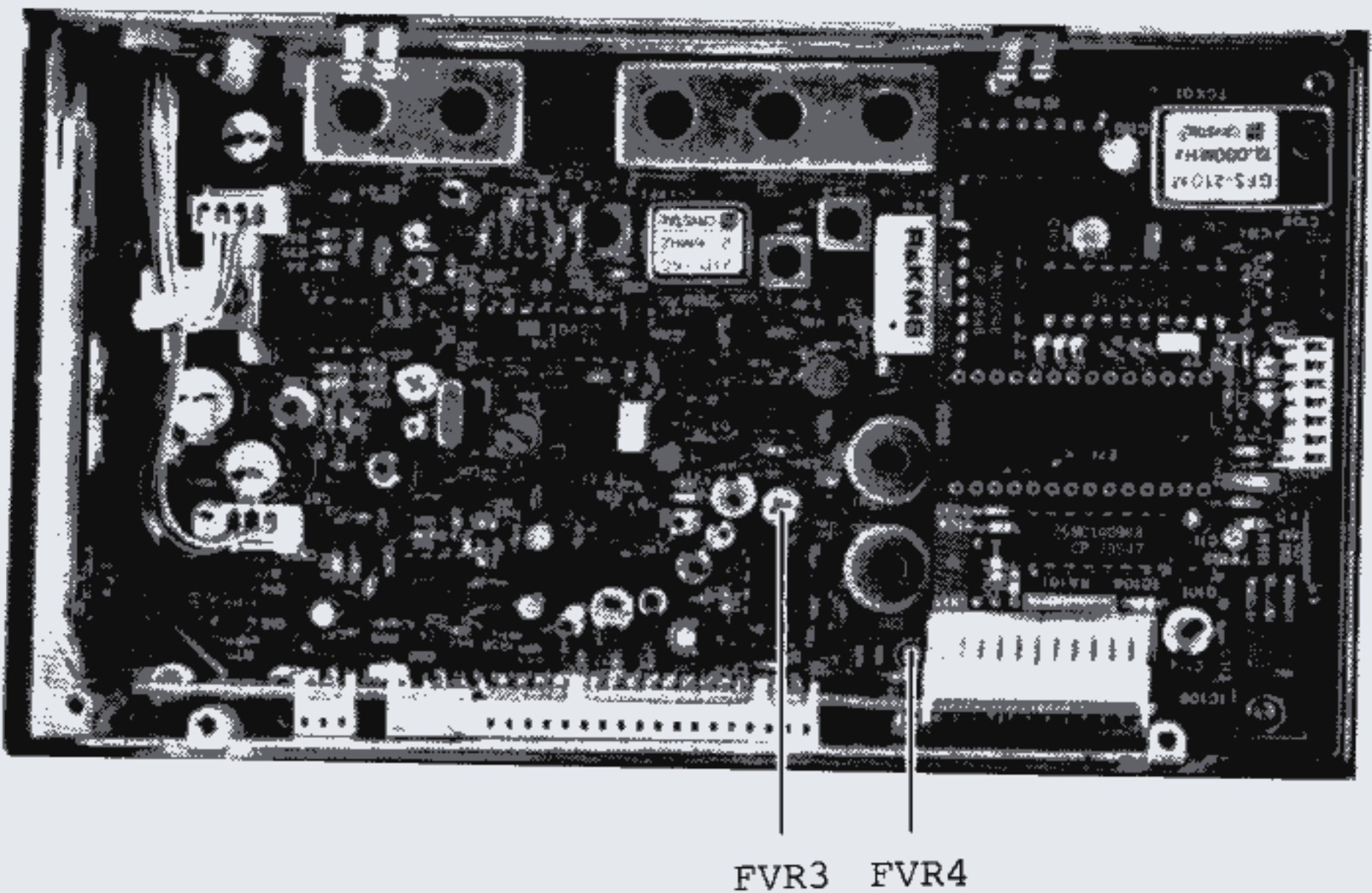

#### (3) Power Protector (No need for readjustment at the site, as a rule)

This has the function of restricting maximum current, with the antenna open.

Adjusting procedure steps are as follows:

- 1) Adjust FVR201 to reduce RF output power to one-half the rated output.

Read collector voltage  $V_{\frac{1}{2}}$  of APC transistor (2SA1359) on a voltmeter connected to the collector.

- 2) Unplug antenna cable from the connector. Adjust FVR201 for maximum radio power output.
- 3) Under this condition, adjust FVR202 so as to make collector voltage ( $V_0$ ) of 2SA1359 equal to the voltage under condition 1.

That is,  $V_0 = V_{\frac{1}{2}}$

- 4) On completion of FVR202 adjustment, plug ANT connector into the mating connector and restore power to the rated value with FVR201.

(4) Microphone Compressor Circuit (No need for readjustment at the site, as a rule.)

- 1) Prepare the testing 34-PIN Remote Control Cable (Option) and interconnect Main Unit and Controller with the cable.
- 2) Inject an AF signal at -14 dBm (1 kHz) into the microphone connector.

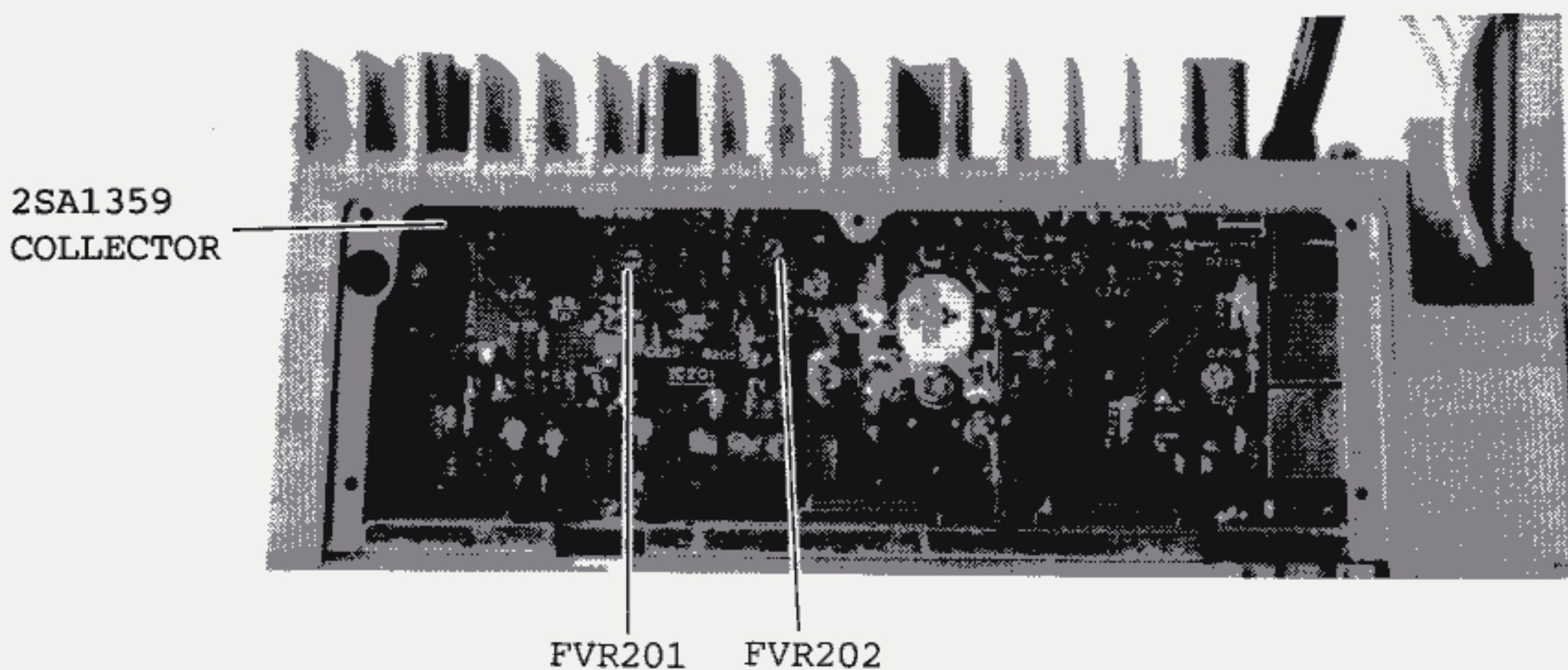

- 3) Connect level meter to pins (20) and (21) on CN6P (pins (20) and (21) on terminal unit CN6S on the radio side may be substituted).

Adjust FVR401 so as to make the output level of (20), (21) 200 mV  $\pm$ 20 mV.

- 4) Lower the microphone input level to -34 dBm (1 kHz) and check the level -10 dB down.

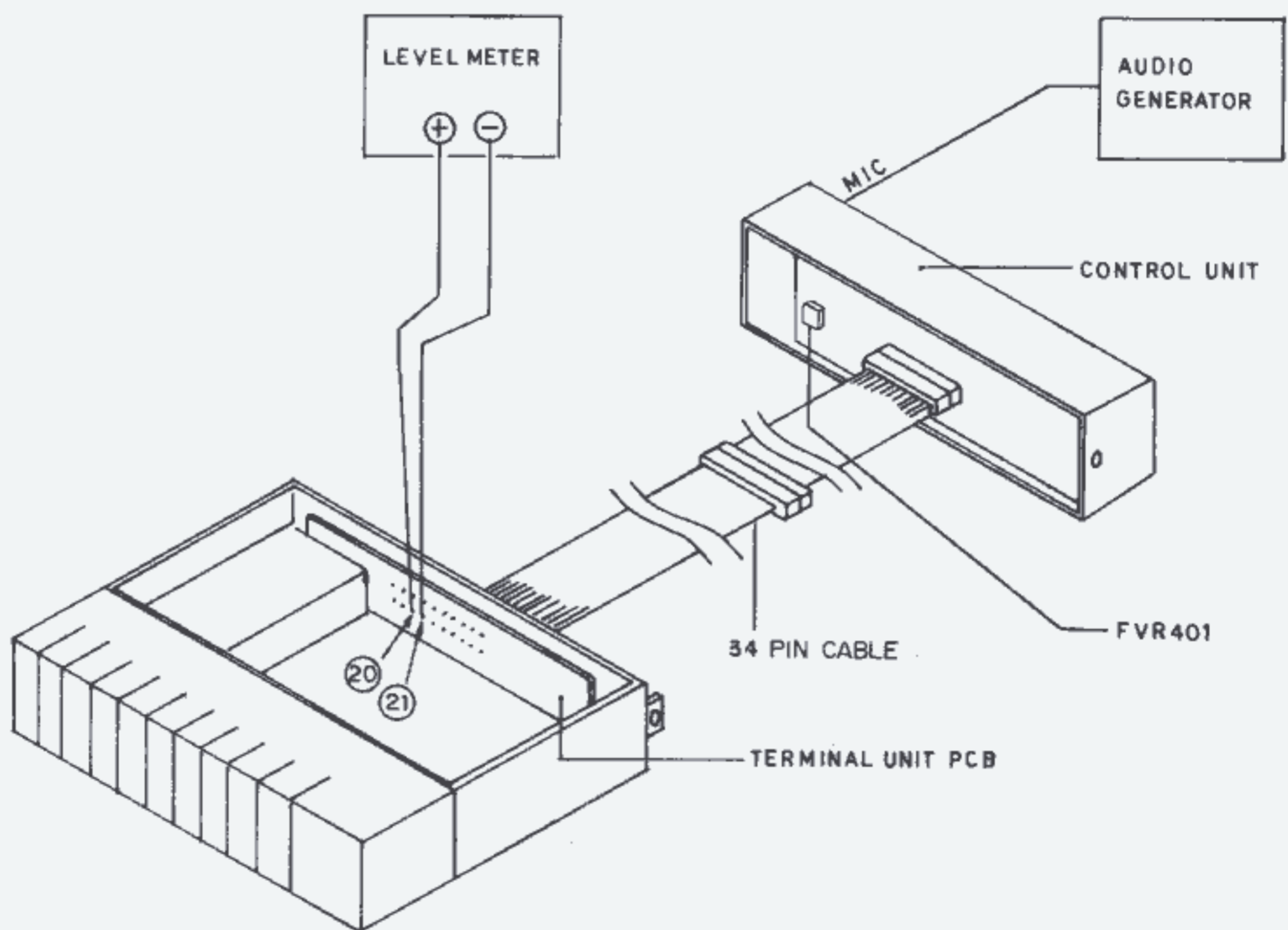

PRECAUTIONS:

Never perform readjustments for items (3) and (4) except when verification is deemed necessary after repair of some integral component, for instance.

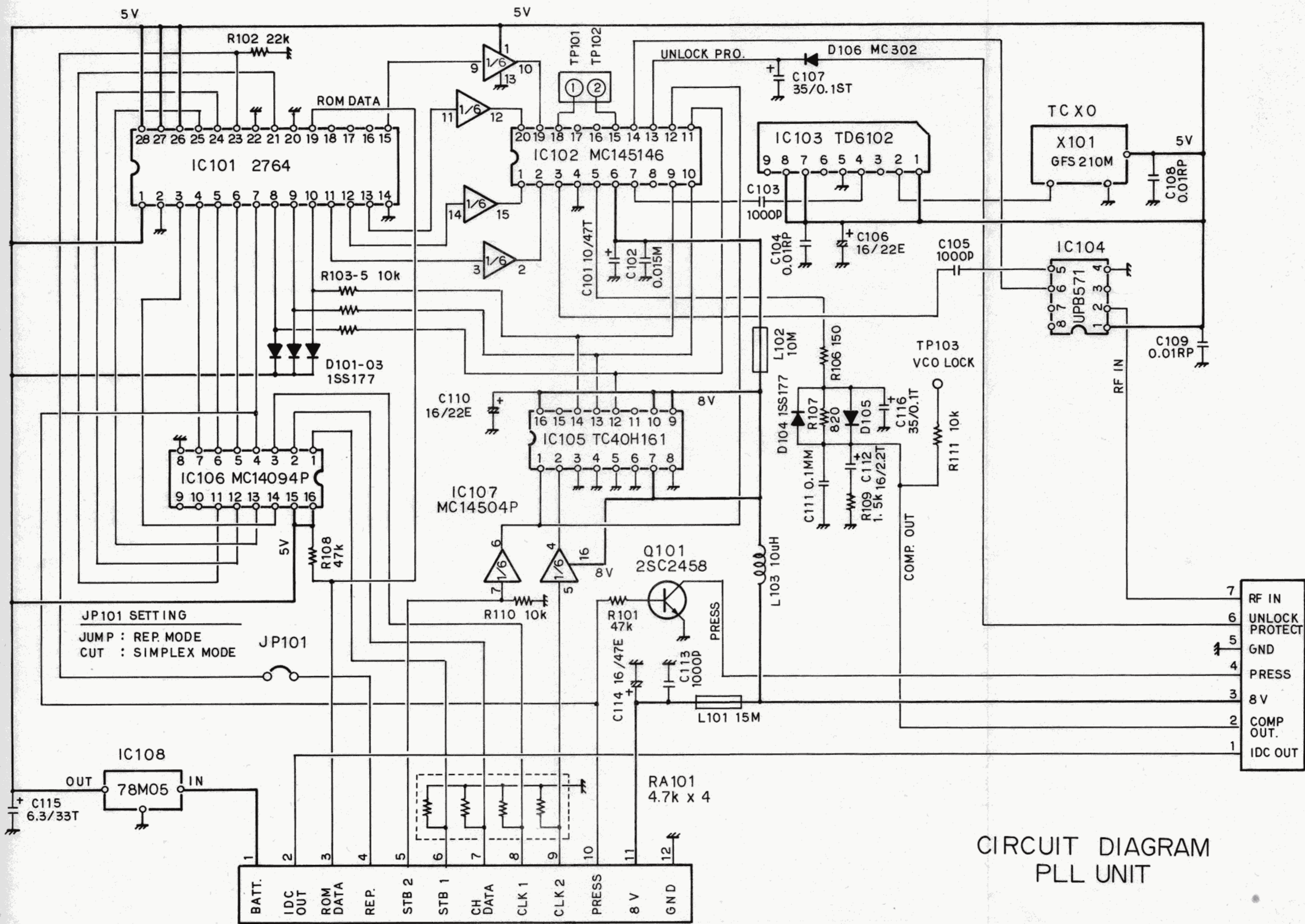

CIRCUIT DIAGRAM  
PLL UNIT

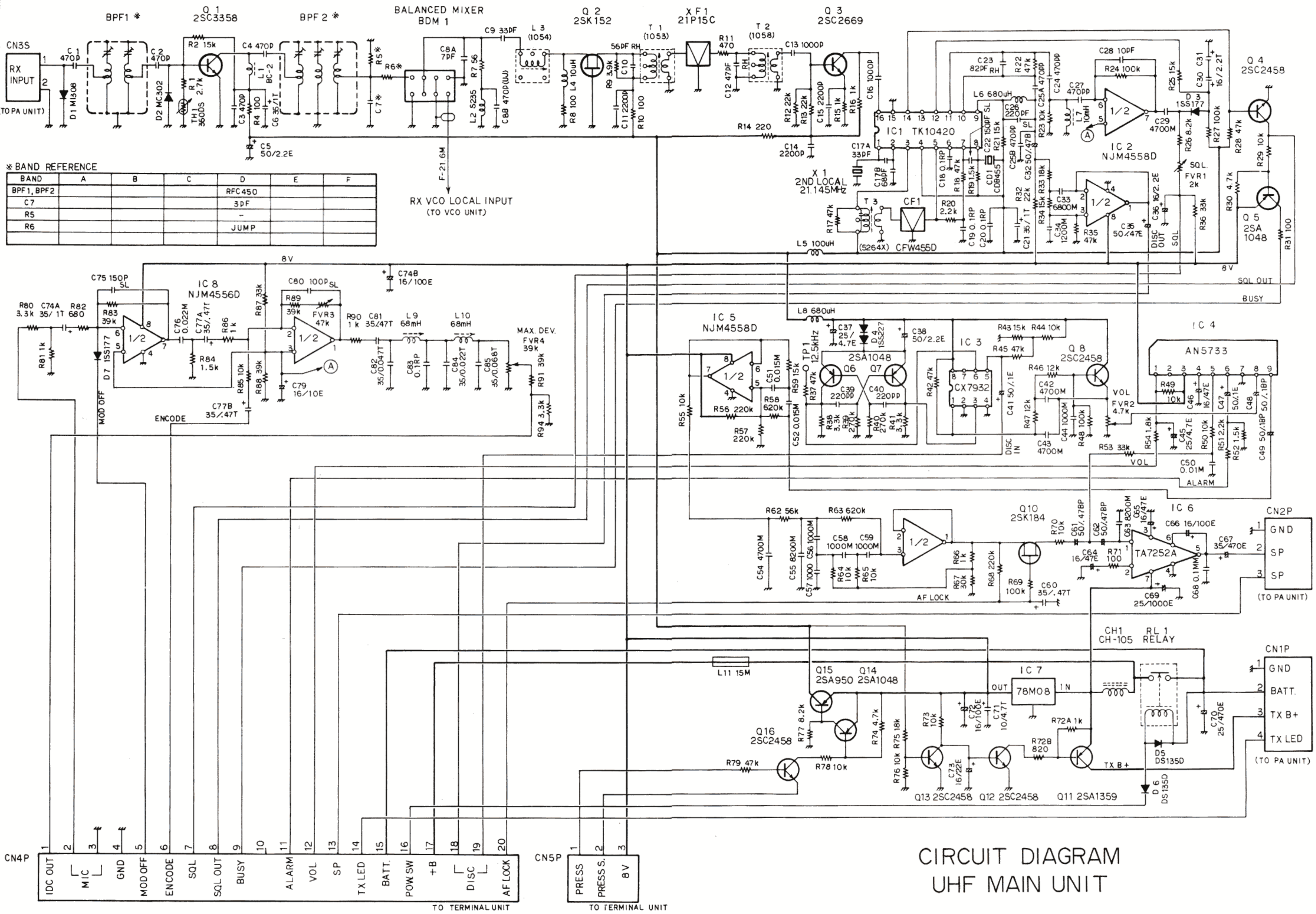

\* BAND REFERENCE

BAND	A	B	C	D	E	F
BPF1, BPF2				RFC450		
C7				3PF		
R5				JUMP		
R6						

CIRCUIT DIAGRAM  
UHF MAIN UNIT



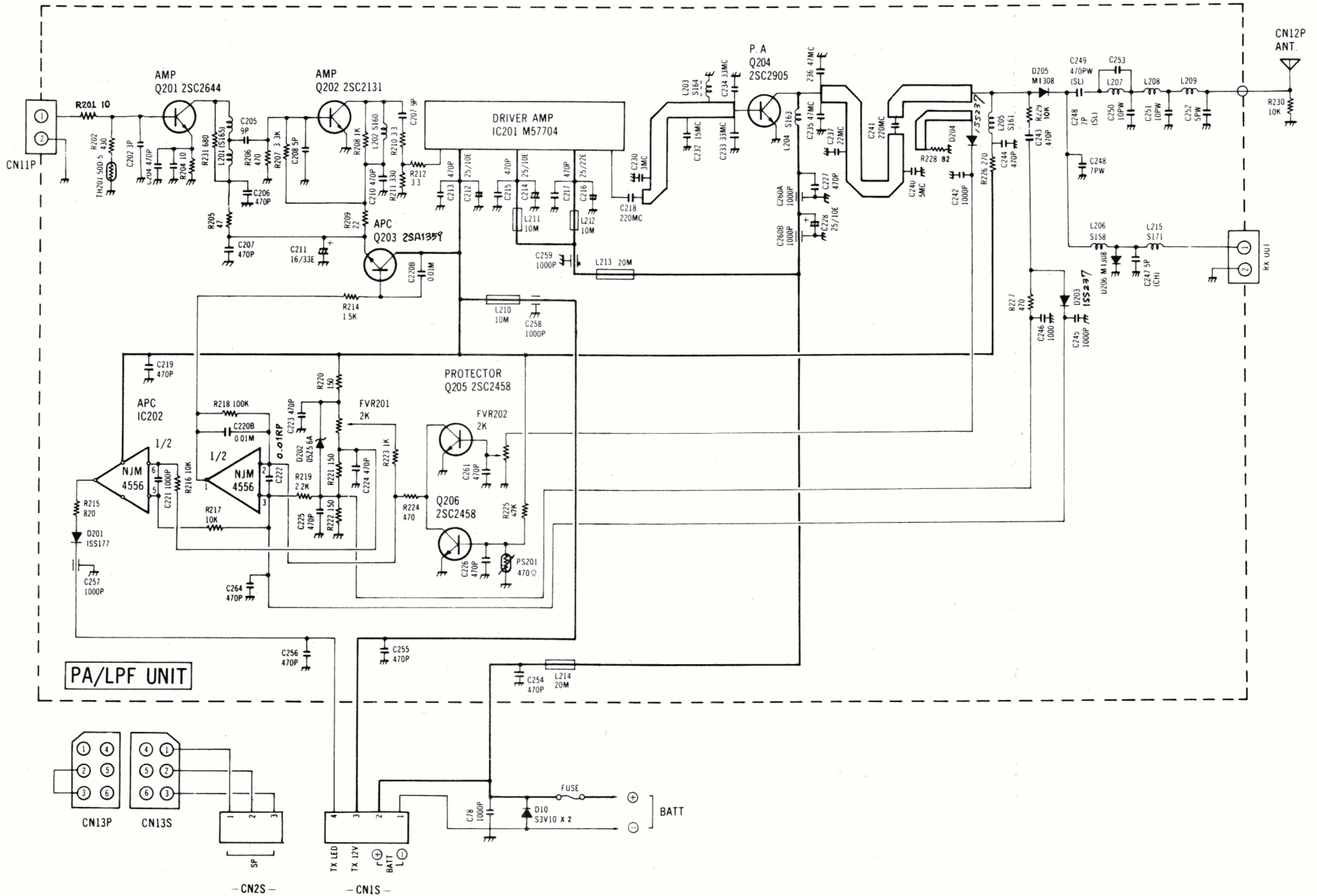

CIRCUIT DIAGRAM  
UHF PA UNIT

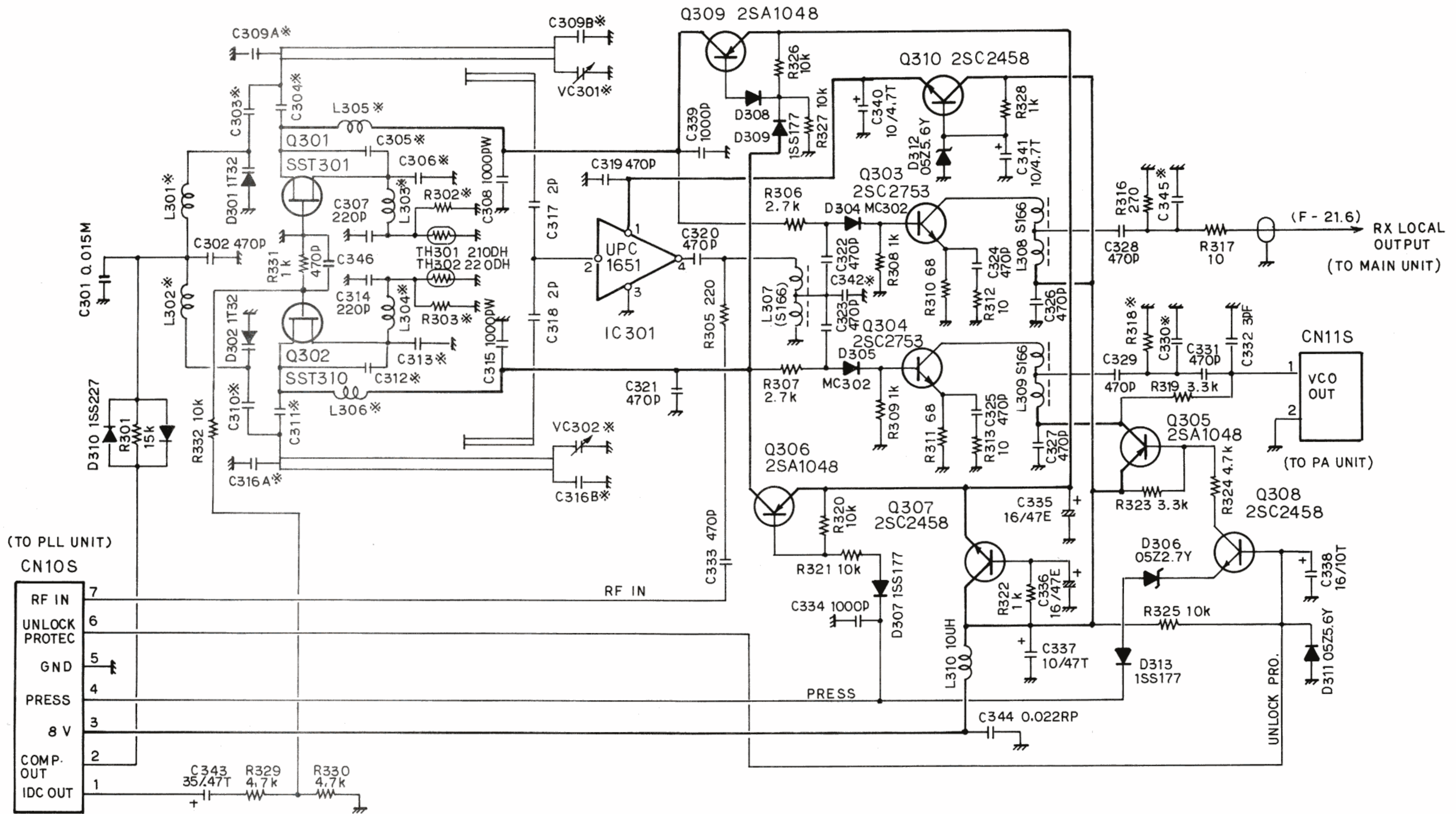

(TO PLL UNIT)

CN10S

RF IN	7
UNLOCK PROTECT	6
GND	5
PRESS	4
8 V	3
COMP. OUT	2
IDC OUT	1

BAND	A	B	C	D	E	F	BAND	A	B	C	D	E	F
L301				1uH			C312				3PF		
L302				1uH			C313				-		
L303				0.47uH			C316A				1.5PF		
L304				0.47uH			C316B				18PF		
L305				S212			C330				-		
L306				S212			C342				5PF		
C303				5PF			C345				-		
C304				11PF			R302				330		
C305				3PF			R303				220		
C306				-			R318				270		
C309A				3PF			VC301-2				20PF		
C309B				18PF			PCB		←	←	07VQUA	07VQUD	→
C310				5PF									
C311				11PF									

CIRCUIT DIAGRAM  
UHF VCO UNIT