

SYMBOLFÖRKLARING
SYMBOLS

Positiv logikkonvention
Positive logic



SYMBOL



BETYDELSE
MEANING

1. Invertering
2. Markerar att signalpulsen har negativ polaritet, dvs logisk "0".

1. Inversion
2. Signifies negative polarity of signal pulse, i.e. logic "0".



Positiv blockering
Positive blocking



Negativ blockering
Negative blocking

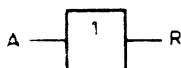

$R = A$

Buffert
Buffer

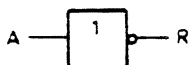

$\bar{R} = A$

Inverterare
Inverter

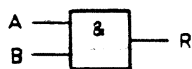
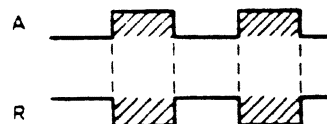

$R = A \cdot B$

OCH-grind
AND-gate

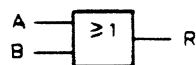
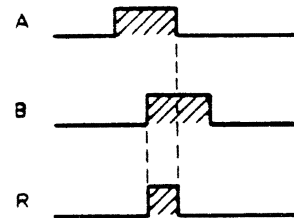

$R = A + B$

ELLER-grind
OR-gate

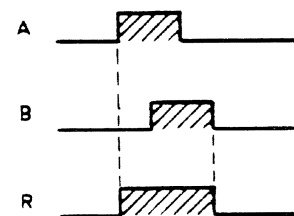

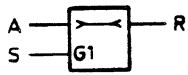

Transmissionsgrind
Transmission gate

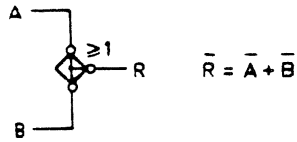
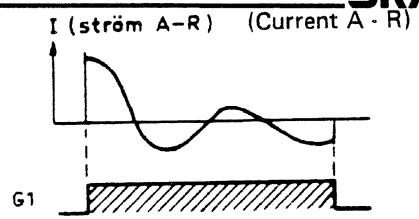

$$\bar{R} = \bar{A} + \bar{B}$$

ELLER-bildande föreningspunkt mellan två utgångar
OR-forming node between two outputs

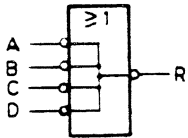
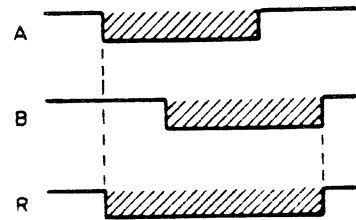

$$\bar{R} = \bar{A} + \bar{B} + \bar{C} + \bar{D}$$

Trådgrind med ELLER-funktion
Wire gate with OR-function

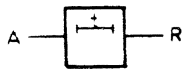

Fördröjning (symetrisk)
Delay (symmetrical)

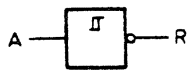
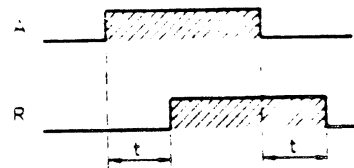

Schmitttrigger
Schmitt-trigger

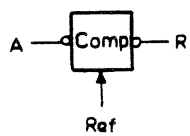
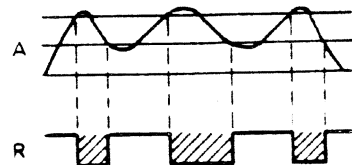

Jämförare
Comparator

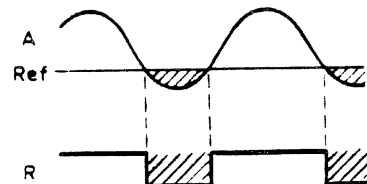

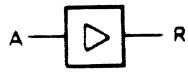

$R = A$

Förstärkare (drivsteg)
Amplifier (driver stage)

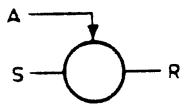

Elektronisk kontakt
Electronic contact

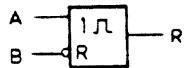

Monostabil vippa
Monostable multivibrator

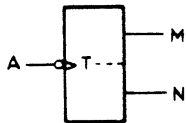

T-vippa
T-flip-flop

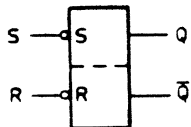

SR-vippa
Om vippan t ex är försedd med flera S-ingångar aktiveras minst en av dessa för att S-ställa vippan.

S/R-flip-flop.
If the flip-flop has several S-inputs, at least one of them must be activated if the flip-flop is to be S-positioned.

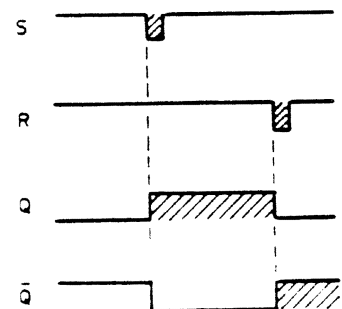
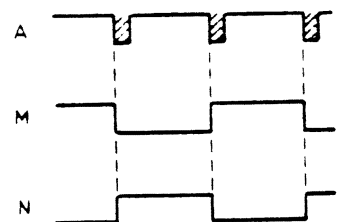
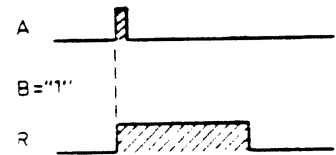
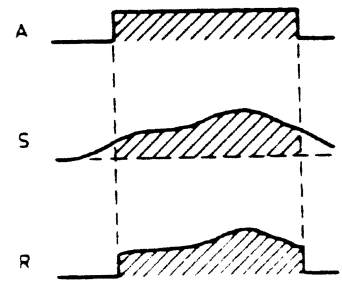

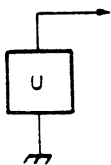

Spänningsnivågivare
Source of voltage level

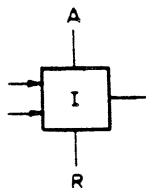

Strömgenerator med två
aktiveringsingångar
Current generator with
two activation inputs

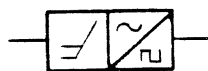

Klippförstärkare
med tröskelsättare
Limiting amplifier with
threshold setter



Diskantsänkande nät
Treble-cutting circuit



Diskanthöjande nät
Treble-increasing circuit



Höpassfilter
High-pass filter



Bandpassfilter
Band-pass filter



Låpassfilter
Low-pass filter

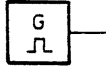

Pulsgenerator
Pulse generator

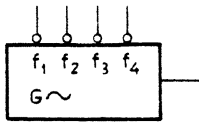

Sinusgenerator med
frekvensstyrningsin-
gångar
Sinus generator with
frequency control inputs

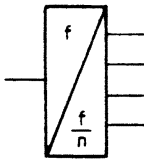

Frekvensomvandlare
Frequency converter

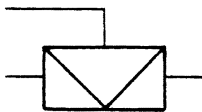

Modulator eller
Demodulator
Modulator or
demodulator



Begränsare
Limiter



Likriktare
Rectifier



Inverterande likspän-
ningsförstärkare
Inverting DC-amplifier

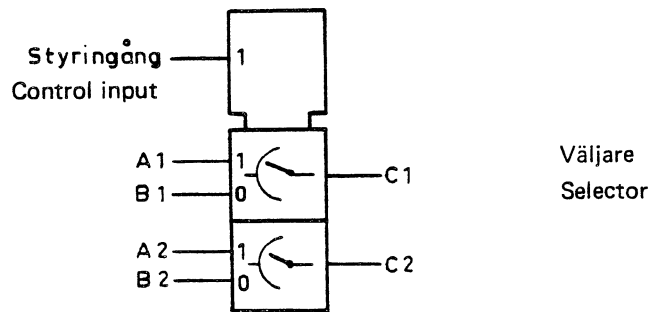

Exempel:
Example:

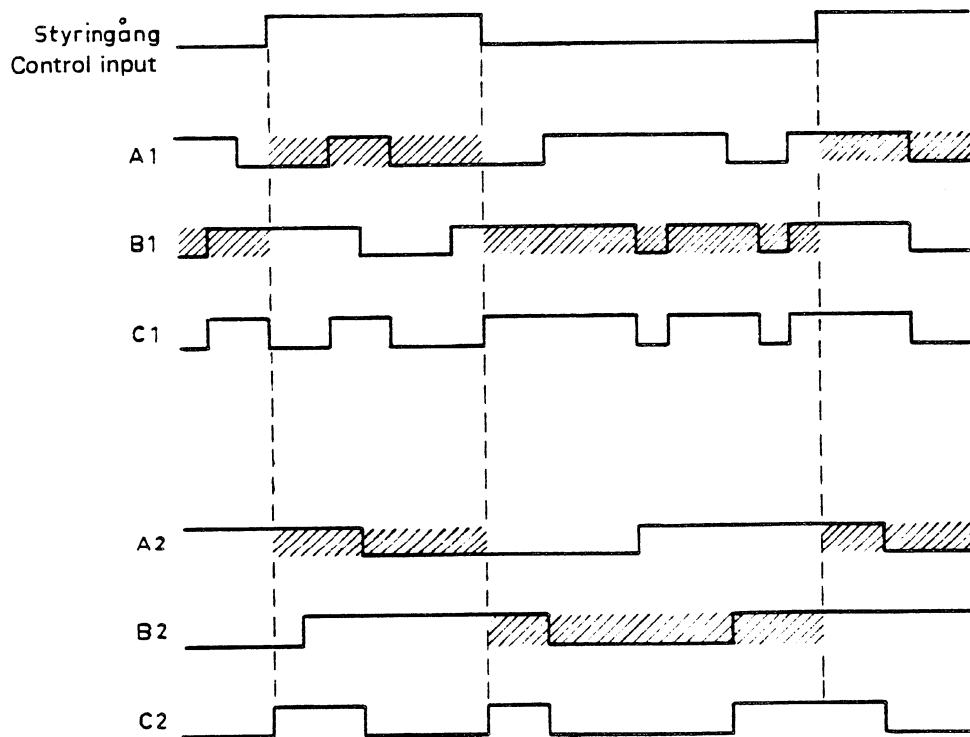

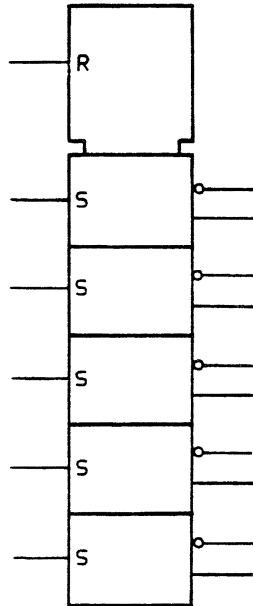

SR-vippor med gemensam R-ingång

SR-flip-flops with common R-input

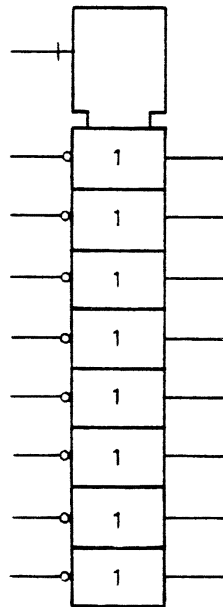

Inverterare med gemensam blockeringsingång. Signal med logiskt "1"-värde på blockeringsingången ger logiskt "0"-värde på samtliga utgångar.

Inverter with common blocking input. A signal with logic "1"-value at the blocking input produces a logic "0"-value at all exits.

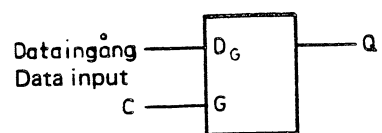

D-vippa
D-flip-flop

Exempel:
Example:

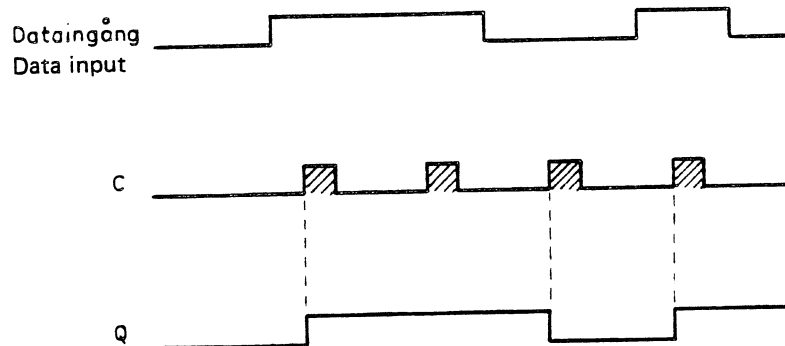

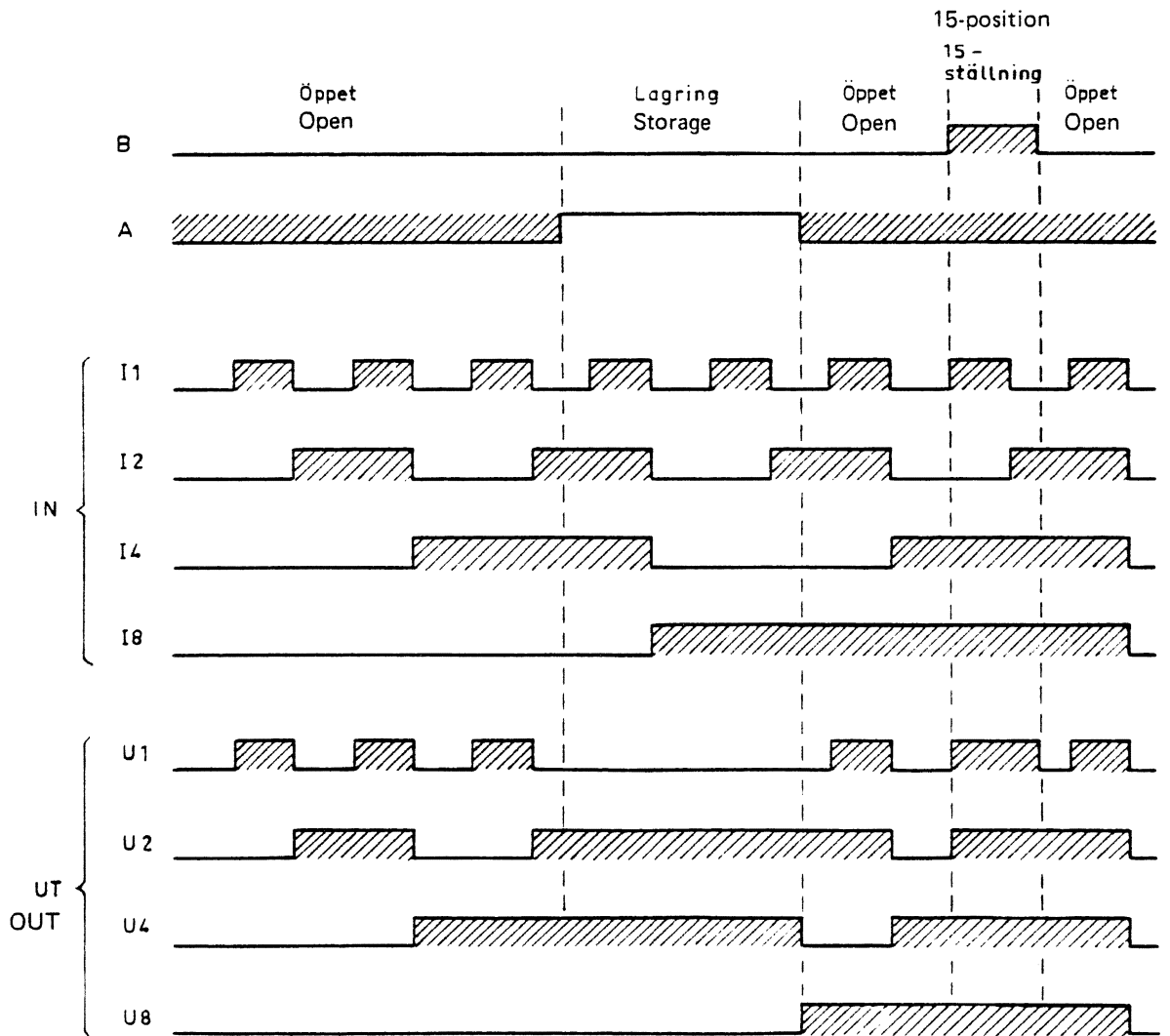
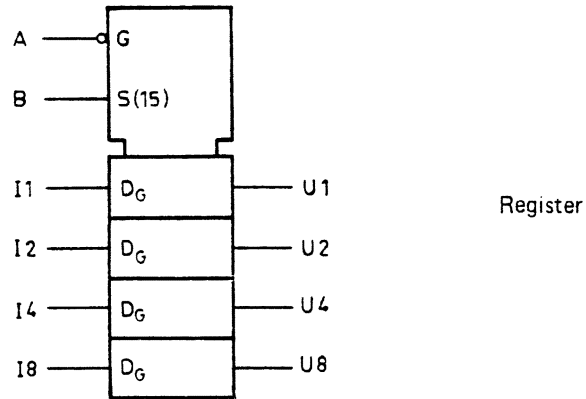

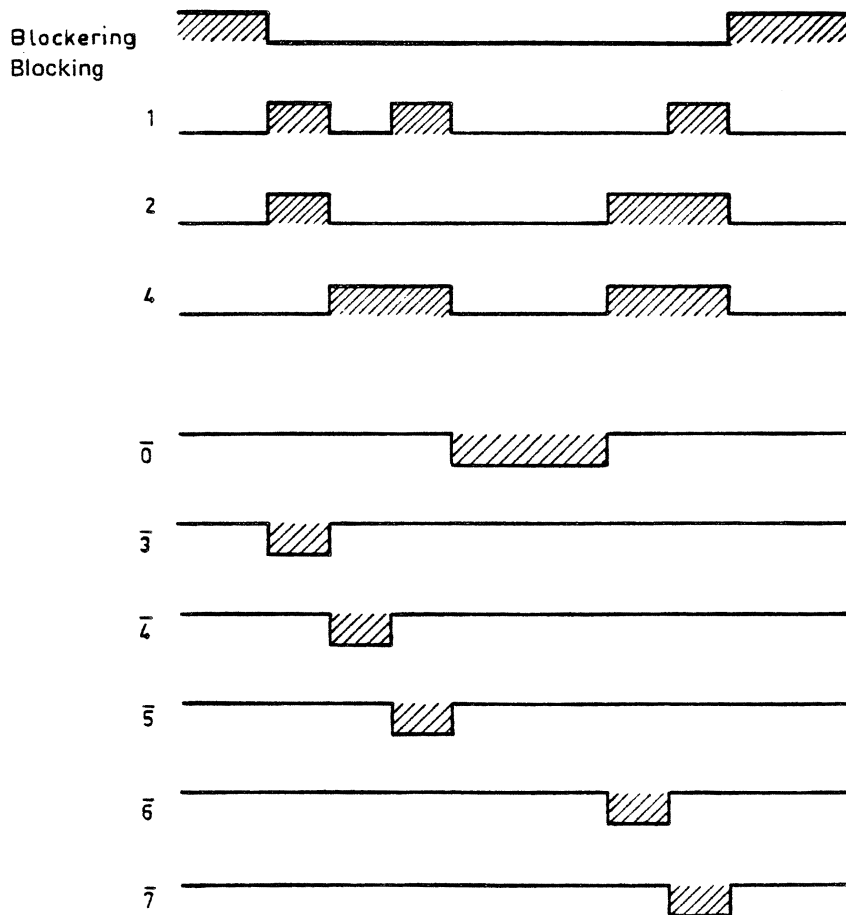
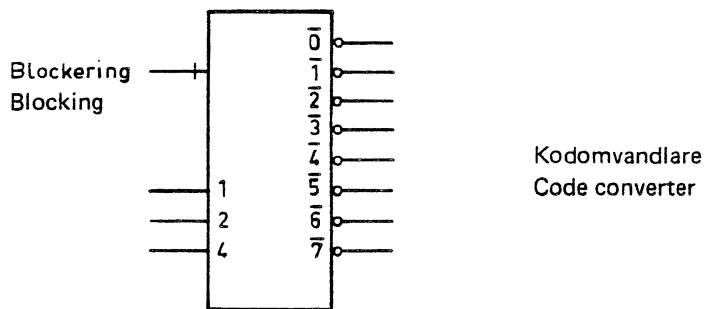

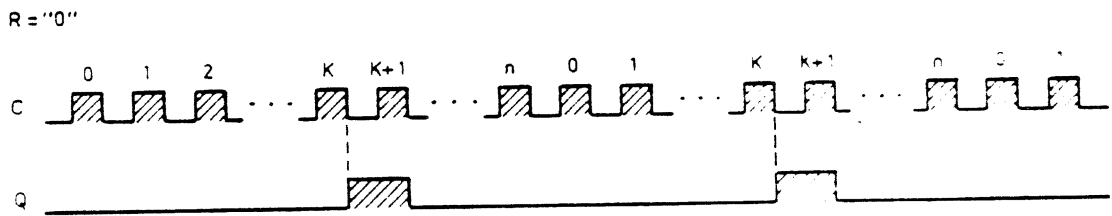
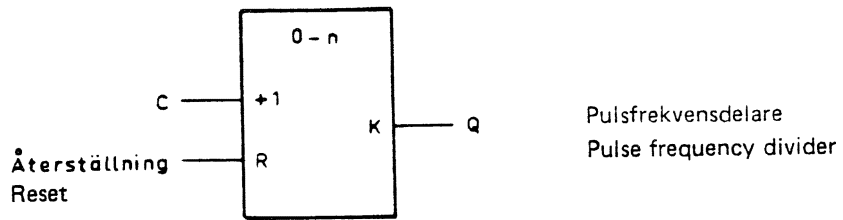

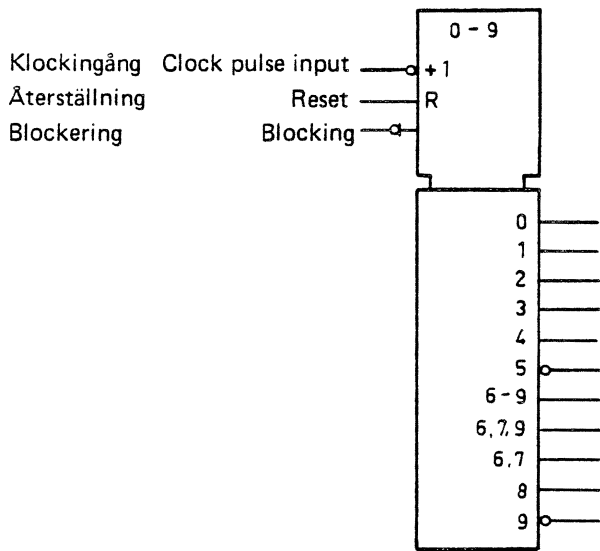

Decimalräknare
10 steg
Decimal counter
10 steps

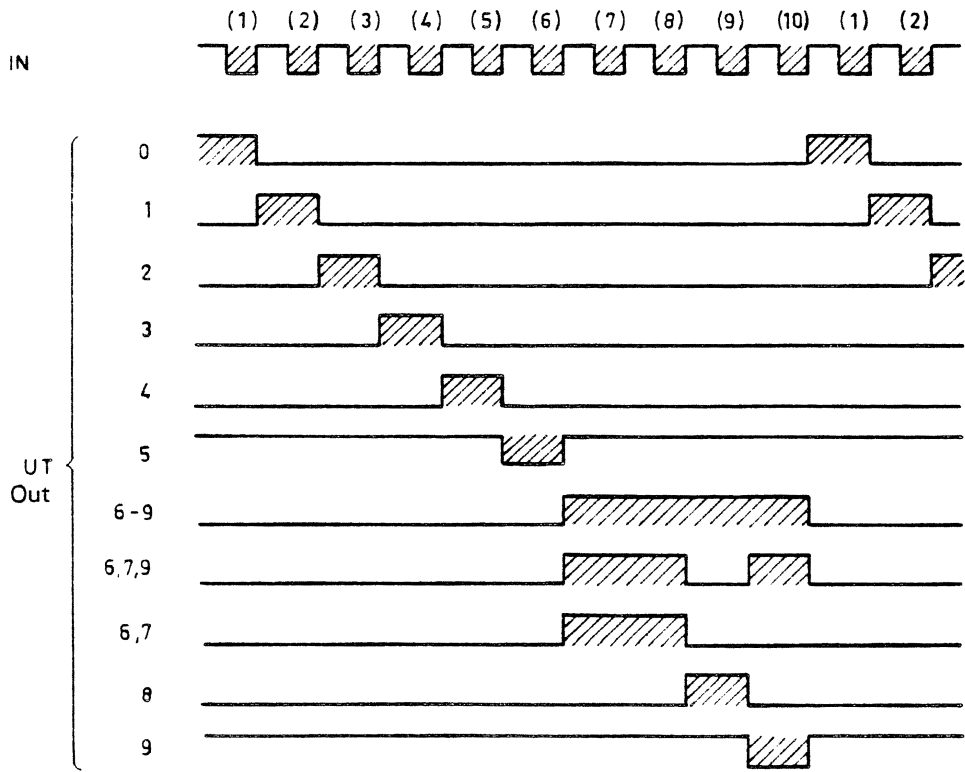

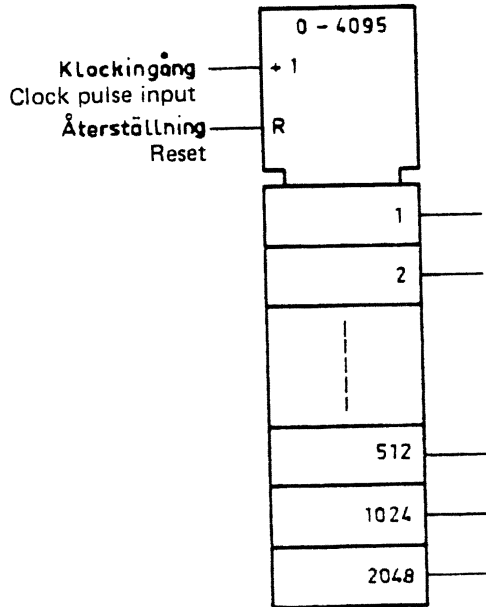

Binärräknare 4096 steg
Binary counter, 4096 steps