



Mobile Communications

SERIAL
PROGRAMMING
KIT TQ3370

Maintenance Manual

TABLE OF CONTENTS

	<u>Page</u>
DESCRIPTION	1
OUTLINE DIAGRAMS	
TQ3370 Assembly	4
Circuit Board A1	8
SCHEMATIC DIAGRAMS	
TQ3370 Assembly	5
Circuit Board A1	7
PARTS LIST	9
PC INTERFACE CABLE	11

DESCRIPTION

Serial Programming Kit TQ3370, includes the Serial Programming Interface Module 19D438367G2, 117 Vac Power power supply 19B800850P2, and Interface Module to PC Computer Interface Cable 19B235027P1. TQ3370-220 Serial Programming Kit includes the same components except that the 117 Vac Power Supply is replaced with 220 Vac Power Supply 19B800888P1. The Interface Module-to-Radio Programming Cables, must be ordered separately.

The Serial Programmer Interface Module provides the interface between GE mobile and personal radios and an IBM-compatible personal computer. The interface converts the RS-232 computer input and output levels to the 5-Volt CMOS levels of the radios. The RS-232 to 5-Volt conversion is accomplished by integrated circuit U1. Data inputs to U1 are protected from static "spikes" by series resistors and back to back diodes.

Data from the computer is applied to the Interface Module through J5 on the printed circuit board A1. This data is buffered by open collector driver transistors and applied to the radio through radio connector A1-J4. The outputs are lightly pulled up to 5-Volts by 100k resistors and isolated from the connector by 100 ohm resistors.

Data from the radio is coupled through A1-J4 where it is buffered by the high voltage inputs of U3. The inputs to U3 are protected by series resistors and back to back diodes. The 5-Volt CMOS outputs of U3 are applied to U1, which converts the 5-Volt inputs to RS-232 output levels that are applied to the computer through A1-J5. The inputs are pulled up to 5-Volts by 10k resistors.

Radio Connector A1-J4 provides for both true and inverted data lines. The inverted lines are marked by an asterisk (*) after their function. A radio will have either a true or inverted signal; it will not use both. Whenever an inverted signal is used, the true signal must be tied to ground. This prevents the normally high true input from masking the inverted signal at OR gate U2.

Jacks J1 and J2 provide access to Rx Audio and Mic Hi. Switch S3 provides for a Push-to-Talk function. Jack J3 permits the Interface Module to be powered from an external power supply. The connector is compatible with Power supply 19B800850P2. The Interface Module may also be used to provide A+ and a regulated 5-Volts to the radio.

The 3370 Interface Module also provides a regulated 12-Volt output for programming radio flash memory. This regulator is controlled by the computer's DTR line. When DTR is positive (the normal state for an active communications program) the supply is turned off. When DTR is negative, the supply is turned on. Q1, a power mosfet, provides the switch function. The input for this regulator comes in on pin 6 and 18 of radio connector A1-J4. This is to guarantee that the flash voltage is not applied to the radio before it is turned on. The regulator consists of two stages. If the input is less than 13.6V, the step up switcher of U4 is used to boost it up. If the input is above this threshold, the U4 is kept disabled. R12 and R13 set U4's threshold level. This provides the input to U5, a 78L12 regulator. It converts its input into a tightly regulated 12-Volt output. This voltage then goes out on pin 5 of radio connector A1-J4.

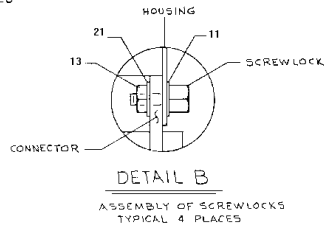
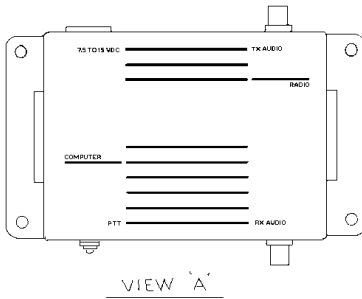
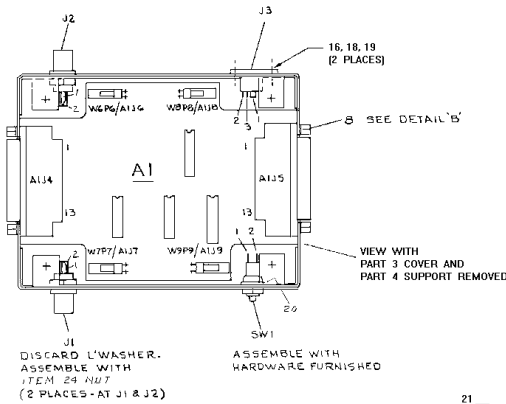
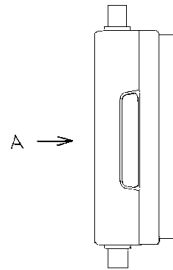
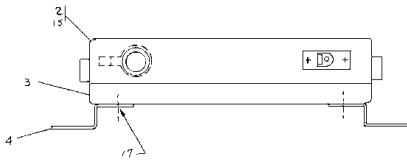

NOTE: 1. DISCARD UNUSED HARDWARE SUPPLIED WITH SCREWLOCK KIT
2. USE ITEM 7 AT J1 & J2 (PIN 2) FOR GROUP 1 ONLY.

OUTLINE DIAGRAM TQ3370 Assembly

(19D438367, Rev. 7)

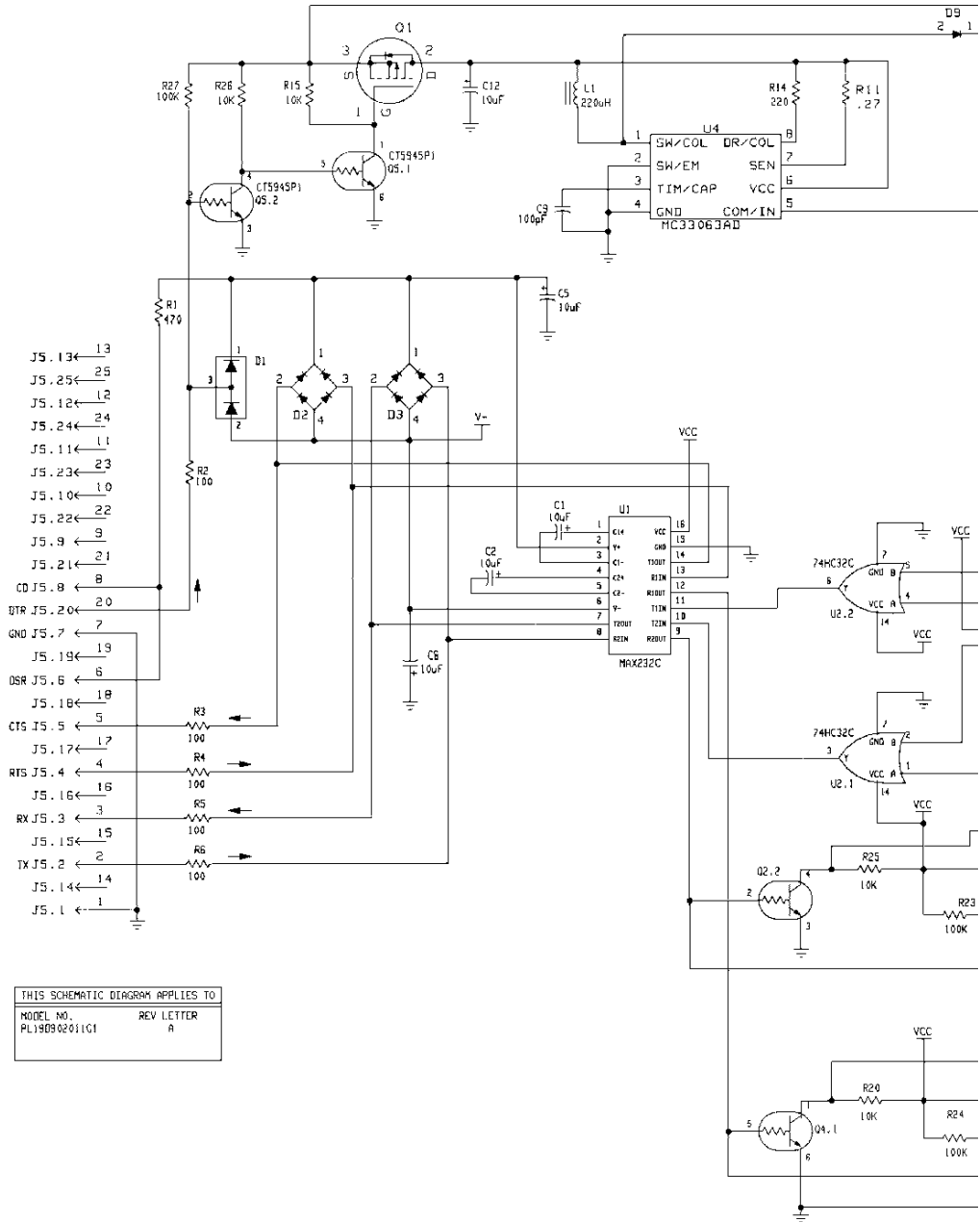

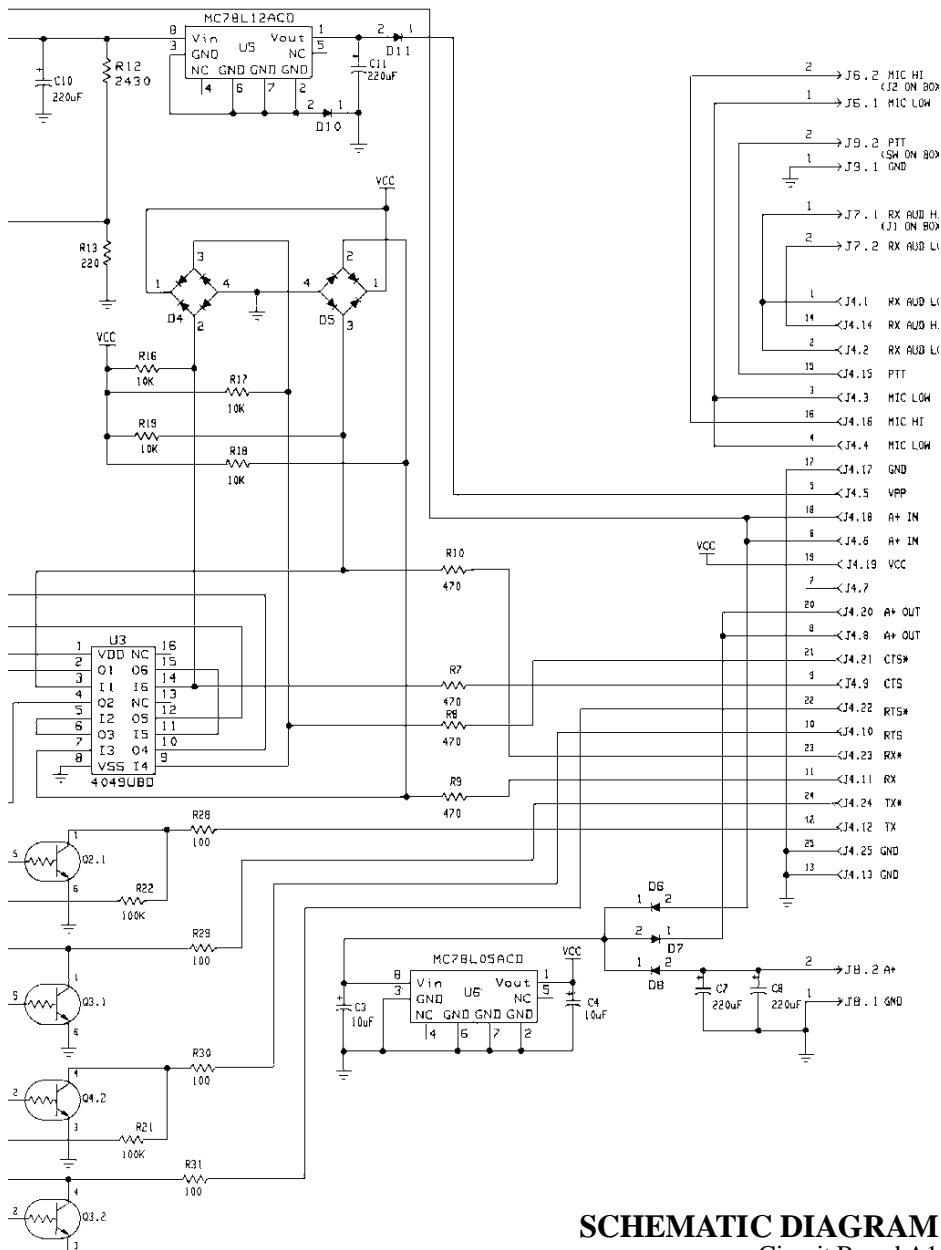

SCHEMATIC DIAGRAM
 Circuit Board A1
 19D904011G1

(19D904012, Rev. 3)

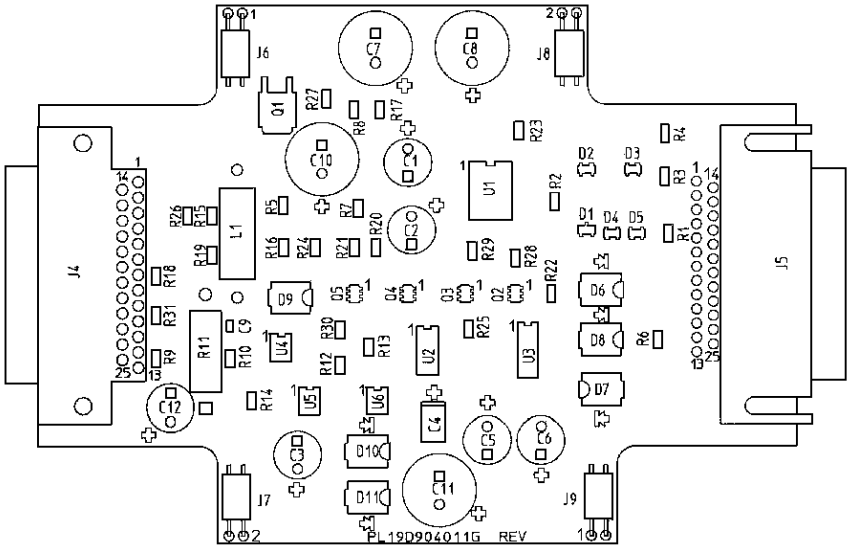

(19D904011, Rev. 2)

LEAD IDENTIFICATION FOR

D1

(SOT) DIODE
(TOP VIEW)
(3-C, A)

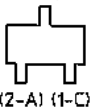

LEAD IDENTIFICATION FOR

D2, D3, D4, AND D5

(SOT) DIODE
(TOP VIEW)

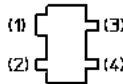

LEAD IDENTIFICATION FOR

Q1

(DPAK) TRANSISTORS
(TOP VIEW)



OUTLINE DIAGRAM
Circuit Board A1

PARTS LIST
TQ3370
SERIAL PROGRAMMING KIT
ISSUE 2

SYMBOL	PART NO.	DESCRIPTION
A1		SERIAL PROGRAMMING INTERFACE MODULE 19D438367G2 SERIAL PROGRAMMING BOARD 19D904011G1
		----- CAPACITORS -----
C1 thru C3	19A703314P10	Electrolytic: 10 μ F -10+50%, 50 VDCW; sim to Panasonic LS Series.
C4	19A705205P7	Tantalum: 10 μ F, 25 VDCW; sim to Sprague 293D.
C5 and C6	19A703314P10	Electrolytic: 10 μ F -10+50%, 50 VDCW; sim to Panasonic LS Series.
C7 and C8	19A701225P3	Electrolytic: 220 μ F, -10+50%, 25 VDCW.
C9	19A702061P61	Ceramic: 100 pF \pm 5%, 50 VDCW, temp coef 0 + or - 30 PPM.
C10 and C11	19A701225P3	Electrolytic: 220 μ F, -10+50%, 25 VDCW.
C12	19A703314P10	Electrolytic: 10 μ F -10+50%, 50 VDCW; sim to Panasonic LS Series.
		----- DIODES -----
D1	19A700053P2	Silicon: 2 Diodes in Series; sim to BAV99.
D2 thru D5	19A149615P1	Silicon: Diode Bridge; sim to BGX50A.
D6 thru D11	19A702977P2	Silicon; sim to Motorola MBRS340T3.
		----- JACKS -----
J4	19B209727P26	Connector plug, power receptacle, 25 contacts; sim to AMP 2006604-1.
J5	19B209727P6	Power plug, 25 contacts; sim to AMP 206584-1.
J6 thru J9	19A704852P132	Printed wire board, two-part; sim to Molex 22-12-2024.
		----- INDUCTORS -----
L1	19A149806P4	Reactor: 220 μ H \pm 15%; sim to Dale Electronics IHD-1-220.
		----- TRANSISTORS -----
Q1	RYN122608/1	Transistor.
Q2 thru Q5	19A705945P1	Silicon, Dual NPN: sim to R OHM 1MH4.
		----- RESISTORS -----
R1	19B800607P471	Metal film: 470 ohms \pm 5%, 1/8 w.
R2 thru R6	19B800607P101	Metal film: 100 ohms \pm 5%, 1/8 w.
R7 thru R10	19B800607P471	Metal film: 470 ohms \pm 5%, 1/8 w.
R11	19A700050P6	Wire wound: .27 ohms, 2w.
*R12	19B800607P242	Metal film: 2.4K ohms \pm 5%, 1/8 w.

*COMPONENTS ADDED, DELETED OR CHANGED BY PRODUCTION CHANGES

SYMBOL	PART NO.	DESCRIPTION
R13 and R14	19B800607P221	Metal film: 220 ohms $\pm 5\%$, 1/8 w.
R15 thru R20	19B800607P103	Metal film: 10K ohms $\pm 5\%$, 1/8 w.
R21 thru R24	19B800607P104	Metal film: 100K ohms $\pm 5\%$, 1/8 w.
R25 and R26	19B800607P103	Metal film: 10K ohms $\pm 5\%$, 1/8 w.
R27	19B800607P104	Metal film: 100K ohms $\pm 5\%$, 1/8 w.
R28 thru R31	19B800607P101	Metal film: 100 ohms $\pm 5\%$, 1/8 w.
----- INTEGRATED CIRCUITS -----		
U1	19A149446P2	Digital: Transmitter/Receiver; sim to MAX232C.
U2	19A703483P311	Digital, high speed CMOS.
U3	19A700176P101	Digital: Hex Inverting Buffer/Converter; sim to 4049UBD.
U4	19A705941P1	Linear, DC to DC Converter; sim to Motorola MC33063AP1.
U5	19A704971P12	Positive Voltage Regulator, 12 volt; sim to MC78L12ACD.
U6	19A704971P9	Positive Voltage Regulator, 5 volt; sim to MC78L05ACD.
----- JACKS -----		
*J1 and J2	19A115938P25	Connector, coax: BNC Series, 500 VRMS.
J3	19B800783P2	Receptacle, power: sim to Hosiden HECO-757-01-020.
----- PLUGS -----		
P6		Part of W6.
P7		Part of W7.
P8		Part of W8.
P9		Part of W9.
----- SWITCHES -----		
SW1	7481654P6	Pushbutton: single pole, normally open, 1/10 amp at 115 VAC or 1/2 amp at 115 VAC; sim to Grayhill 30-1.
----- CABLES -----		
W6 thru W9	19B234998G1	Cable, programming. Includes:
	19A700041P28	Shell.
	19A700041P26	Contact: 22-30 AWG; sim to Molex 08-50-0113.
----- MISCELLANEOUS -----		
	19C336927G1	Housing.
	19C336929P1	Cover.
	19B234985P1	Support.
	19B209727P46	Screwlock: No. 4-40; sim to AMP 205818-2.
	N404P25B6	Lockwasher, internal tooth, 1/4 inch.
	N402P5B6	Washer: narrow, steel.
	N404P11B6	Lockwasher, internal tooth, No. 4.
	7141225P2	Nut, Hex: 4-40.
		SERIAL PROGRAMMING KIT INCLUDES:
	19B235027P1	PC Interface Cable.
	19B800850P2	Power Supply - 121 VAC.
	19B800888P1	Power Supply - 220 VAC (TQ3370-220 Only).

PRODUCTION CHANGES

Changes in the equipment to improve performance or to simplify circuits are identified by a "Revision Letter" which is stamped after the model number of the unit. The revision stamped on the unit includes all previous revisions. Refer to the Parts List for the descriptions of parts affected by these revisions.

REV. A- INTERFACE MODULE, 19D438367G2
Isolate BNC connectors from ground. Delete solder terminal 4036835P5. J1 & J2 were 19A702270P1.

REV. A- SERIAL PROGRAMMING BOARD, 19D904011G1
Present a high impedance on Vpp line. Add diodes D10 and D11. R12 was 19B800607P222, 2.2 K. PWB changed.

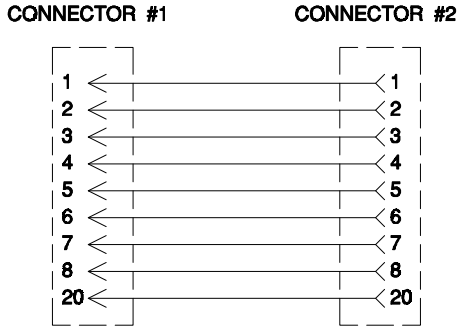
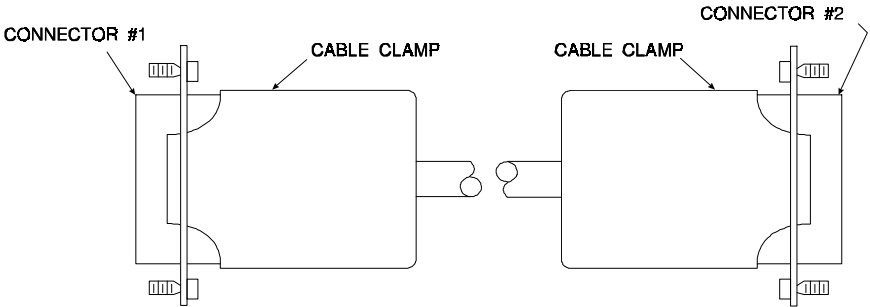

INTERFACE CABLE
19B235027P1



Ericsson GE Mobile Communications Inc.
Mountain View Road • Lynchburg, Virginia 24502

Printed in U.S.A.